

Valcourt

OWNER'S MANUAL

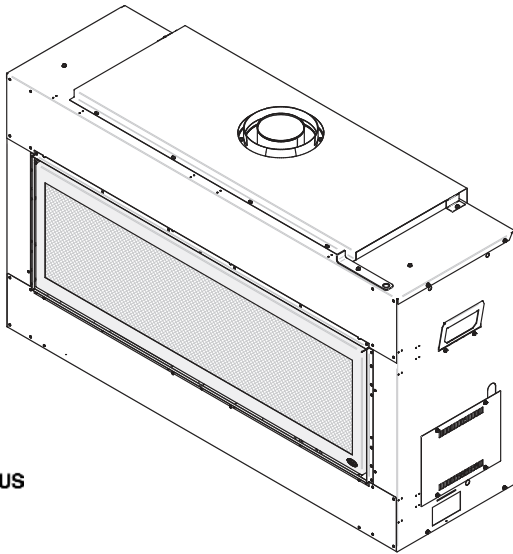

MODEL

L48 (FG00001)

**DIRECT VENT
ZERO CLEARANCE
GAS FIREPLACE HEATER**

MULTIFUNCTION REMOTE (MF)



We suggest that our gas hearth products be installed and serviced by professionals who are certified in the U.S. by the National Fireplace Institute (NFI) as NFI Gas Specialist.



! DANGER

HOT GLASS WILL CAUSE BURNS. DO NOT TOUCH GLASS UNTIL COOLED. NEVER ALLOW CHILDREN TO TOUCH GLASS. A barrier designed to reduce the risk of burns from the hot viewing glass is provided with this appliance and shall be installed for the protection of children and other at-risk individuals. NOTE : Barrier required, may be sold separately.

WARNING

FIRE OR EXPLOSION HAZARD

- Failure to follow safety warnings exactly could result in serious injury, death or property damage.
- Do not store or use gasoline or other flammable vapors and liquids in the vicinity of this or any other appliance.

WHAT TO DO IF YOU SMELL GAS

- Do not try to light any appliance.
- Do not touch any electrical switch; do not use any phone in your building.
- Leave the building immediately.
- Immediately call your gas supplier from a neighbor's phone. Follow the gas supplier's instructions.
- If you cannot reach your gas supplier, call the fire department.
- Installation and service must be performed by a qualified installer, service agency or the gas supplier.

WARNING

- If not installed, operated and maintained in accordance with the manufacturer's instructions, this product could expose you to substances in fuel or from fuel combustion which can cause death or serious illness.

- This appliance may be installed in an aftermarket, permanently located, manufactured home (USA only) or mobile home, where not prohibited by local codes.

- This appliance is only for use with the type of gas indicated on the rating plate.

- This appliance is not convertible for use with other gases, unless a certified kit is used.

- Fuels used in gas, wood-burning or oil fired appliances, and the products of combustion of such fuels, contain chemicals known to the State of California to cause cancer, birth defects or other reproductive harm. For more information go to www.P65warnings.ca.gov/

READ AND KEEP THIS MANUAL FOR REFERENCE

Dealer:

Installer:

Phone Number:

Serial Number:

THANK YOU FOR CHOOSING THIS GAS FIREPLACE.

As one of North America's largest and most respected stove and fireplace manufacturers, Stove Builder International takes pride in the quality and performance of all its products.

The following pages provide general advice on gas heating, detailed instructions for safe and effective installation, and guidance on how to get the best performance from this fireplace.

It is mandatory that this gas burning hearth product be installed and serviced by a qualified installer, a service agency or the gas supplier.

Contact local building or fire officials about restrictions and installation inspection requirements in your local area. A building permit might be required for this installation .

It is also highly recommended to inform your home insurance company. Please read this entire manual before installing and using this fireplace.

 **If this fireplace is not installed properly, combustible materials near it may overheat and catch fire.**

 **To reduce the risk of fire, follow the installation instructions in this manual.**

ONLINE WARRANTY REGISTRATION

If the unit requires repairs during the warranty period, proof of purchase must be provided. The purchase invoice must be kept. The date indicated on it establishes the warranty period. If it cannot be provided, the warranty period will be determined by the date of manufacture of the product. It is also highly recommended to register the warranty online at

<https://www.valcourtinc.com/en/warranty/warranty-registration/>

Registering the warranty will help to quickly find the information needed on the unit.



TABLE OF CONTENTS

Certification plate.....	6
1. Safety Information.....	7
Carbon monoxide poisoning hazard	8
Safety information for users of propane gas	9
2. General Information	11
2.1 Appliance Certification	11
2.2 Clearance	11
2.3 Fuel.....	12
2.4 Qualified Installing/repairing Agency.....	12
2.5 Odor risk with polymer materials	12
3. Lighting Instructions	13
4. Operating Instructions	14
4.1 Noise coming from the fireplace	15
4.2 First operation	15
4.3 Controls	15
MAINTENANCE AND SERVICE	
5. Service call	24
6. Invisimesh barrier and glass door removal.....	24
6.1 Glass cleaning	25
7. General	25
7.1 Fireplace cleaning	26
7.2 Inspection	26
7.3 Light Bulbs replacement	28
7.4 Gas valve	29
7.5 Maintenance Frequency	31
7.6 Maintenance venting	32
7.7 Control System Troubleshooting	33
8. Parts View and Parts List.....	35
Appendix 1: Accessories	39
Waranty	42

CERTIFICATION PLATE



STANDARDS / NORMES D'ESSAI:

Certified to / Certifié selon ANSI Z21.88 / CSA 2.33
 Certified to / Certifié selon CAN/CSA - P.4.1
 Category 1

LISTED VENTED GAS FIREPLACE HEATERS FOYER À GAZ HOMOLOGUÉ

FOR USE WITH GAS
 POUR UTILISATION AU GAZ

REFER TO INTERTEK'S DIRECTORY OF BUILDING PRODUCTS
 FOR DETAILED INFORMATION
 SE RÉFÉRER AU RÉPERTOIRE DES PRODUITS HOMOLOGUÉS
 D'INTERTEK POUR PLUS D'INFORMATION

MODEL / MODÈLE:

L48

Serial Number
 No. de Série

1

CONTACT LOCAL BUILDING OFFICIALS ABOUT THE
 RESTRICTIONS AND INSTALLATION INSPECTION IN
 YOUR AREA.
 COMMUNIQUER AVEC LES AUTORITÉS LOCALES DU
 BÂTIMENT ET DE LA PRÉVENTION DES INCENDIES
 AU SUJET DES RESTRICTIONS D'INSTALLATION DANS
 VOTRE SECTEUR.

TYPE OF GAS / GENRE DE GAZ:	PROPANE	NAT
ORIFICE DRILL SIZE / GROSSEUR TROU DE L'ORIFICE:	50 DMS (1.95 mm)	31 DMS (3.50 mm)
MAX. INPUT / PUISSANCE MAXIMALE D'ENTRÉE:	34 000 BTU/HR (9.96 kW-h)	38 000 BTU/HR (11.14 kW-h)
MIN. INPUT / PUISSANCE MINIMALE D'ENTRÉE:	27 000 BTU/HR (7.91 kW-h)	25 000 BTU/HR (7.33 kW-h)
GAS SUPPLY PRESSURE / PRESSION LIGNÉ À GAZ		
MAXIMUM PRESSION / PRESSION MAXIMALE	14.0 IN. W.C. (3.48 kPa)	14.0 IN. W.C. (3.48 kPa)
MINIMUM FOR PURPOSE OF ADJUSTMENT /		
MINIMUM POUR PERMETTRE L'AJUSTEMENT À L'ENTRÉE:	11.0 IN. W.C. (2.74 kPa)	4.5 IN. W.C. (1.12 kPa)
MANIFOLD / PRESSION DES GAZ	10.0 IN. W.C. (2.49 kPa)	3.5 IN. W.C. (0.87 kPa)

INSTALL AND USE ONLY IN ACCORDANCE WITH SBI STOVE BUILDER INTERNATIONAL INSTALLATION AND OPERATION INSTRUCTIONS.
 L'INSTALLATION ET L'OPERATION DOIT SE FAIRE SELON LES INSTRUCTIONS D'INSTALLATION ET D'UTILISATION DE SBI FABRICANT DE POÊLES INTERNATIONAL.

PREVENT HOUSE FIRES

PRÉVENEZ LES INCENDIES

- Not for use with solid fuel.
- Keep burner and control compartment clean.
- Do not overfire unit.
- For use with glass doors certified with the appliance only.
- This fireplace may be installed as an aftermarket, permanently located, manufactured home (USA only) or mobile home, where not prohibited by local codes.
- This appliance must be installed in accordance with manufacturer's instructions and local codes. In the absence of local codes, follow the current NFPA 54/ANSI Z223.1 or CSA B149.1 installation codes.
- Acceptable for installation from 0-4500 FT. (0-1372 M.)
- Pas conçu pour utilisation avec combustible solide.
- Maintenir le brûleur et le compartiment de contrôle propre.
- Ne pas surchauffer le foyer.
- Pour utilisation seulement avec la vitre certifiée avec le produit.
- Cet appareil peut être installé dans une maison préfabriquée (mobile) déjà installé si les règlements locaux le permettent.
- Cet appareil doit être installé conformément aux instructions du fabricant et aux codes locaux. En l'absence de codes locaux, suivez les codes d'installation actuels NFPA 54/ANSI Z223.1 ou CSA B149.1.
- Installation acceptable de 0-4500 FT. (0-1372 M.)

MINIMUM CLEARANCES TO COMBUSTIBLE MATERIALS /
 DÉGAGEMENTS MINIMUM AUX MATÉRIAUX COMBUSTIBLES

Sidewall / Mur latéral [1]:	8 in./po. (203 mm)
Ceiling / Plafond [1]:	38 in./po. (965 mm)
Mantles, shelves, etc./ Manteaux, tablettes, etc.:	[2]
Center of vent to nearest outside corner or obstruction / Centre de l'évent au coins extérieur ou obstruction la plus proche:	13 3/4 in./po. (349 mm)

[1] From door opening. / À partir de l'ouverture de la porte.

[2] See installation instructions for specified clearances for projections above appliance. / Voir les instructions d'installation pour les dégagements spécifiques au projections au-dessus de l'appareil.

MINIMUM FRAMED OPENING FOR INSTALLATION OF THIS APPLIANCE IS /
 OUVERTURE MINIMALE DU BÂTIS POUR L'INSTALLATION DE CET APPAREIL

Height / Hauteur:	34 5/16 in./po. (872 mm)	Depth / Profondeur:	22 1/2 in./po. (572 mm)
Front width / Largeur avant:	61 in./po. (1550 mm)	Rear width / Largeur arrière:	61 in./po. (1550 mm)

Blower electrical rating / Puissance électrique du ventilateur: 115V, 60Hz, 60W, less than / moins de 3A.

For use only with barrier part no / Utiliser seulement avec grillage no. SE71059



WARNING: This product can expose you to carbon monoxide, which is known to the State of California to cause cancer, birth defects or other reproductive harm.
 (For more information go to www.p65warnings.ca.gov)

CAUTION

- DO NOT USE A BLOWER INSERT, HEAT EXCHANGER INSERT OR OTHER ACCESSORY NOT APPROVED FOR USE WITH THIS HEATER.
- HOT WHILE IN OPERATION.
- DO NOT TOUCH. KEEP CHILDREN, CLOTHING AND FURNITURE AWAY.
- DO NOT INSTALL IN ALCOVE OR CLOSET.
- WHEN THE VENT - AIR INTAKE SYSTEM IS REMOVED FOR SERVICING REFER TO INSATLLATION INSTRUCTIONS AND OWNER'S MANUAL FOR PROPER RESEALING OR REINSTALLATION.
- WHENEVER THIS APPLIANCE IS NOT USED FOR EXTENDED PERIODS, TURN GAS CONTROL KNOB TO "OFF" POSITION.
- THIS VENTED GAS FIREPLACE HEATER IS NOT FOR USE WITH AIR FILTERS.

ATTENTION

- NE PAS UTILISER DE VENTILATEUR, ÉCHANGEUR DE CHALEUR OU AUTRES ACCESSOIRES NON APPROUVÉ AVEC CET UNITÉ.
- CHAUD EN FONCTIONNEMENT.
- NE PAS TOUCHER. GARDER LES ENFANTS, LES VÊTEMENTS ET LES MEUBLES ÉLOIGNÉS.
- NE PAS INSTALLER DANS UN ALCÔVE OU UN PLACARD.
- LORSQUE L'ÉVENT / ENTRÉE D'AIR SONT ENLEVÉS POUR L'ENTRETIEN, CONSULTER LES INSTRUCTIONS D'INSTALLATION ET D'UTILISATION POUR SCELLER OU RÉINSTALLER DE FAÇON APPROPRIÉE.
- LORSQUE L'APPAREIL N'EST PAS UTILISÉ POUR UNE PÉRIODE PROLONGÉE, FERMER L'ARRIVÉE DES GAZ EN TOURNANT LA VANNE D'ARRÊT EN POSITION «OFF».
- CETTE UNITÉ NE DOIT PAS ÊTRE UTILISÉE AVEC DES FILTRES À AIR.

Made in St-Augustin-de-Desmaures (Qc), Canada
 28/10/2019 (# 888888)



Fabriqué à St-Augustin-de-Desmaures (Qc), Canada
 28/10/2019 (# 888888)
 27793

1. Safety Information



DO NOT OPERATE THIS APPLIANCE WITHOUT GLASS FRONT PANEL INSTALLED.

1. Due to high temperatures, the appliance should be located out of traffic and away from furniture and draperies.
2. Children and adults should be alerted to the hazards of high surface temperature and should stay away to avoid burns or clothing ignition.
3. Young children should be carefully supervised when they are in the same room as the appliance. Toddlers, young children, and others may be susceptible to accidental contact burns. A physical barrier is recommended if there are at-risk individuals in the house. To restrict access to a fireplace or stove, install an adjustable safety gate to keep toddlers, young children, and other at-risk individuals out of the room and away from hot surfaces.
4. For appliances requiring a barrier, as determined under Clause 5.15.4: "A barrier designed to reduce the risk of burns from the hot viewing glass is provided with this appliance and shall be installed for the protection of children and other at-risk individuals."
5. If the barrier becomes damaged, the barrier shall be replaced with the manufacturer's barrier for this appliance.
6. Clothing or other flammable material should not be placed on or near the appliance.
7. Any safety screen, guard, or barrier removed for servicing an appliance must be replaced prior to operating the appliance (see Clause 4.1.6).
8. Installation and repair should be done by a qualified service person. The appliance should be inspected before use and at least annually by a professional service person. More frequent cleaning might be required due to excessive lint from carpeting, bedding material, et cetera. It is imperative that control compartments, burners, and circulating air passageways of the appliance be kept clean.

WARNING	
	Do not operate fireplace with the glass front removed, cracked or broken.

WARNING	
	<ol style="list-style-type: none">1. The use of substitute glass will void all product warranties.2. Care must be taken to avoid breakage of the glass.3. Under no circumstances should this fireplace be operated without the glass front or with a broken glass front. Replacement of the glass (with gasket) as supplied by the manufacturer should be done by a qualified service person.4. Do not abuse the glass by striking or hitting it.

WARNING	
	<p>Do not use ammonia based or abrasive cleaners on glass. Do not attempt to clean glass when glass is hot.</p>



CARBON MONOXIDE POISONING HAZARD

FAILURE TO FOLLOW THE STEPS OUTLINED BELOW FOR EACH APPLIANCE CONNECTED TO THE VENTING SYSTEM BEING PLACED INTO OPERATION COULD RESULT IN CARBON MONOXIDE POISONING OR DEATH.

THE FOLLOWING STEPS SHALL BE FOLLOWED FOR EACH APPLIANCE CONNECTED TO THE VENTING SYSTEM BEING PLACED INTO OPERATION, WHILE ALL OTHER APPLIANCES CONNECTED TO THE VENTING SYSTEM ARE NOT IN OPERATION:

1. Seal any unused openings in the venting system.
2. Inspect the venting system for proper size and horizontal pitch, as required in the National Fuel Gas Code ANSI Z223.1/NFPA 54 or the National Gas and Propane Installation Code CSA B149.1 and these instructions. Determine that there is no blockage or restriction, leakage, corrosion and other deficiencies which could cause an unsafe condition.
3. As far as practical, close all building doors and windows and all doors between the space in which the appliance(s) connected to the venting system are located and other spaces of the building.
4. Close fireplace dampers.
5. Turn on clothes dryers and any appliance not connected to the venting system. Turn on any exhaust fans, such as range hoods and bathroom exhausts, so they are operating at maximum speed. Do not operate a summer exhaust fan. Follow the lighting instructions. Place the appliance being inspected into operation. Adjust the thermostat so appliance is operating continuously.
6. Test for spillage from draft hood equipped appliances at the draft hood relief opening after 5 minutes of main burner operation. Use the flame of a match or candle.
7. If improper venting is observed during any of the above tests, the venting system must be corrected in accordance with National Fuel Gas Code, ANSI Z223.1/NFPA and/or National Gas and Propane Installation Code, CSA B149.1.
8. After it has been determined that each appliance connected to the venting system properly vents when tested as outlined above, return doors, windows, exhaust fans, fireplace dampers and any other gas-fired burning appliance to their previous conditions of use.

SAFETY INFORMATION FOR USERS OF PROPANE GAS

Propane is a flammable gas which can cause fires and explosions. In its natural state, propane is odorless and colorless. You may not know all the following safety precautions which can protect both you and your family from an accident. Read them carefully now, then review them point by point with the members of your household. Someday when there may not be a minute to lose, everyone's safety will depend on knowing exactly what to do. If, after reading the following information, you feel you still need more information, please contact your gas supplier.



If a gas leak happens, you should be able to smell the gas because of the odorant put in the Propane Gas. That's your signal to go into immediate action!

- Do not operate electric switches, light matches, use your phone. Do not do anything that could ignite the gas.
- Get everyone out of the building, vehicle, trailer, or area. Do that IMMEDIATELY.
- Close all gas tank or cylinder supply valves.
- Propane Gas is heavier than air and may settle in low areas such as basements. When you have reason to suspect a gas leak, keep out of basements and other low areas. Stay out until firefighters declare them to be safe.
- Use your neighbor's phone and call a trained Propane Gas service person and the fire department.
- Even though you may not continue to smell gas, do not turn on the gas again. Do not re-enter the building, vehicle, trailer, or area.
- Finally, let the service man and firefighters check for escaped gas. Have them air out the area before you return. Properly trained Propane Gas service people should repair the leak, then check and relight the gas fireplace for you.

NO ODOR DETECTED - ODOR FADE

Some people cannot smell well. Some people cannot smell the odor of the chemical put into the gas. You must find out if you can smell the odorant in propane. Smoking can decrease your ability to smell. Being around an odor for a time can affect your sensitivity or ability to detect that odor. Sometimes other odors in the area mask the gas odor. People may not smell the gas odor or their minds are on something else. Thinking about smelling a gas odor can make it easier to smell. **The odorant in Propane Gas is colorless, and it can fade under some circumstances.** For example, if there is an underground leak, the movement of the gas through soil can filter the odorant. Odorants in Propane Gas also are subject to oxidation. This fading can occur if there is rust inside the storage tank or in iron gas pipes.

SAFETY INFORMATION FOR USERS OF PROPANE GAS (CONT'D)

The odorant in escaped gas can adsorb or absorb onto or into walls, masonry and other materials and fabrics in a room. That will take some of the odorant out of the gas, reducing its odor intensity. Propane Gas may stratify in a closed area, and the odor intensity could vary at different levels. Since it is heavier than air, there may be more odor at lower levels. Always be sensitive to the slightest gas odor. If you detect any odor, treat it as a serious leak. Immediately go into action as instructed earlier.

SOME POINTS TO REMEMBER

Learn to recognize the odor of Propane Gas.

Your local Propane Gas Dealer can give you a “Scratch and Sniff” pamphlet. Use it to find out what the propane odor smells like. If you suspect that your Propane Gas has a weak or abnormal odor, call your Propane Gas Dealer.

If you are not qualified, do not light pilot lights, perform service, or make adjustments to appliances on the Propane Gas system. If you are qualified, consciously think about the odor of Propane Gas prior to and while lighting pilot lights or performing service or making adjustments.

Sometimes a basement or a closed-up house has a musty smell that can cover up the Propane Gas odor. Do not try to light pilot lights, perform service, or make adjustments in an area where the conditions are such that you may not detect the odor if there has been a leak of Propane Gas.

Odor fade, due to oxidation by rust or adsorption on walls of new cylinders and tanks, is possible. Therefore, people should be particularly alert and careful when new tanks or cylinders are placed in service. Odor fade can occur in new tanks, or reinstalled old tanks, if they are filled and allowed to set too long before refilling. Cylinders and tanks which have been out of service for a time may develop internal rust which will cause odor fade. If such conditions are suspected to exist, a periodic sniff test of the gas is advisable.

**If you have any question about the gas odor, call your Propane Gas Dealer.
A periodic sniff test of the Propane Gas is a good safety measure under any condition.**

If, at any time, you do not smell the Propane Gas odorant and you think you should, assume you have a leak. Then take the same immediate action recommended above for the occasion when you do detect the odorized Propane Gas.

If you experience a complete “gas out,” (the container is under no vapor pressure), turn the tank valve off immediately. If the container valve is left on, the container may draw in some air through openings such as pilot light orifices. If this occurs, some new internal rusting could occur. If the valve is left open, then treat the container as a new tank. Always be sure your container is under vapor pressure by turning it off at the container before it goes completely empty or having it refilled before it is completely empty.

2. General Information

- This fireplace is supplied as propane gas and is field convertible to natural gas. See instructions packaged with the conversion kit for further information.
- This appliance is designed and approved as a supplemental heater and provides the potential for most energy conservation when used while attended. The use of an alternative primary heat source is advisable.
- This model do not include the variable halogen lighting. However, it may be purchased and installed during or after fireplace installation. Instructions are supplied with the light kit.
- The blower kit is already installed.
- Sample Warnings and Definitions

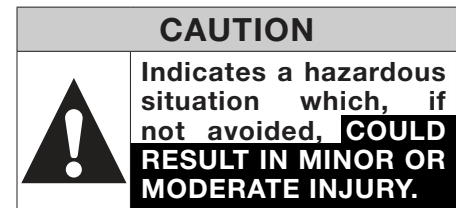
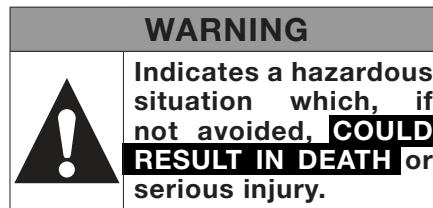
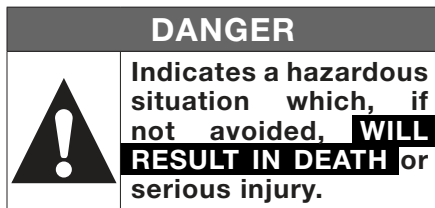

NOTICE: Addresses practices not related to personal injury.

2.1 Appliance Certification

This fireplace is design certified in accordance with American National Standard/CSA Standard ANSI Z21.88/CSA 2.33 and by Intertek as a Direct Vent Gas Fireplace Heater and shall be installed according to the installation instructions.

2.2 Clearance

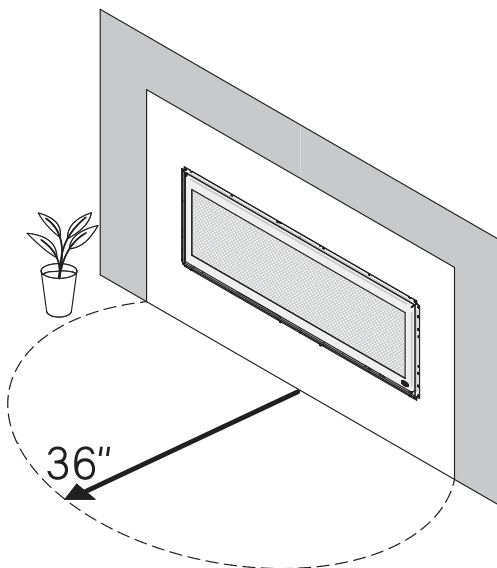

Do not put furniture or any other combustible household objects within 36" of the fireplace front.

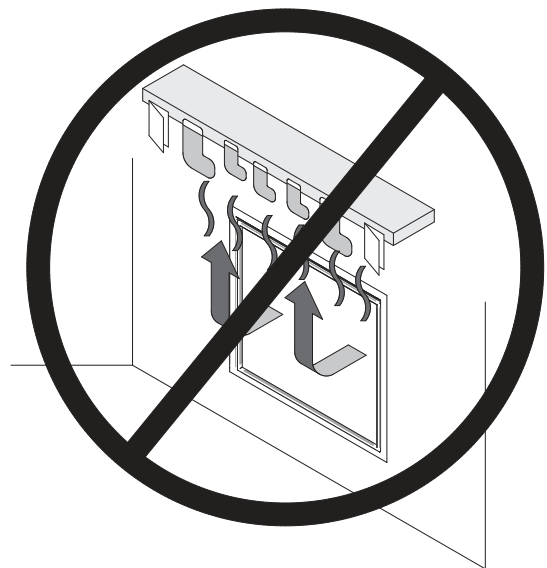

Be careful not to put any decorating objects sensitive to heat too close above or around the fireplace as it gets very hot when operating.

Installing a television above a fireplace

Installing a television above a fireplace has become increasingly popular; however, the area above any fireplace gets hot and most TV manufacturers recommend against placing their products near a heat source. If you install a television above this fireplace, SBI accepts no responsibility for damage or injuries.

Follow the television manufacturer's installation instructions, including any recommendations regarding proximity to heat sources.

If you have a TV above your fireplace, turn off the fireplace and let it cool completely before servicing or touching any buttons on the TV.

2.3 Fuel

WARNING



**This fireplace is NOT FOR USE WITH SOLID FUELS.
Solid fuels could cause personal injury or property damage.**

2.4 Qualified Installing/repairing Agency

Installation and replacement of gas piping, gas utilization equipment or accessories and repair and servicing of equipment **shall be performed only by a qualified agency.**

The term "qualified agency" means any individual, firm, corporation or company which either in person or through a representative is engaged in and is responsible for :

- (a) the installation or replacement of gas piping or
- (b) the connection, installation, repair or servicing of equipment, who is experienced in such work, familiar with all precautions required and has complied with all the requirements of the authority having jurisdiction.

WARNING



**ANY CHANGE TO THIS FIREPLACE OR ITS CONTROLS CAN BE DANGEROUS.
Improper installation or use of the fireplace can cause serious injury or death
from fire, burns, explosions, or carbon monoxide poisoning.**

The installation must conform with local codes or, in the absence of local codes, with the National Fuel Gas Code ANSI Z223.1/ NFPA 54* Natural Gas and Propane Installation Code, or CSA B149.1 in Canada.

Any alteration of the original design, installed other than as shown in these instructions or use with a type of gas not shown on the rating plate is the responsibility of the person and company making the change.

2.5 Odor risk with polymer materials

Do not install any cement boards or other materials that contain polymer based fibers or other polymer materials.

3. Lighting Instructions

FOR YOUR SAFETY READ BEFORE LIGHTING

⚠ WARNING



If you do not follow these instructions exactly, a fire or explosion may result causing property damage, personal injury or loss of life.

- A) This appliance must be lighted with the remote control. When lighting the pilot, follow these instructions exactly.
- B) **BEFORE LIGHTING**, smell around the appliance area for gas. Be sure to smell next to the floor because some gas is heavier than air and will settle on the floor.
- C) Use only the remote control to operate the valve. Never use tools. If valve does not operate, don't try to repair it, call a qualified service technician. Force or attempted repair may result in a fire or explosion.
- D) Do not use this appliance if any part has been underwater. Immediately call a qualified service technician to inspect the appliance and to replace any part of the control system and any gas control which has been underwater.

WHAT TO DO IF YOU SMELL GAS

- Do not try to light any appliance.
- Do not touch any electrical switch.
- Do not use any phone in your building.
- Immediately call your gas supplier from a neighbor's phone. Follow the gas supplier's instructions. If you can not reach your gas supplier, call the fire department.

LIGHTING INSTRUCTIONS

1. **STOP!** Read the safety information above.
2. Turn **OFF** electric power to the appliance.
3. Turn gas shut-off counterclockwise  to **ON** position.
4. Wait ten minutes to clear out any gas. Then smell for gas, including near the floor. If you smell gas, **STOP!** Follow B in the safety information above on this label. If you do not smell gas, go to the next step.
5. Turn **ON** electric power to the appliance.
6. Using the remote control, turn main flame to **ON**. If the pilot does not light within 60 seconds, stop and go back to Step 4
7. If the burner or pilot does not operate properly after several tries, turn the gas control knob clockwise  to **OFF** and call your service technician or gas supplier.
8. Operation of the gas valve, blower, and/or optional light must be controlled by using the hand held remote control. Refer to remote instructions for detailed operation information

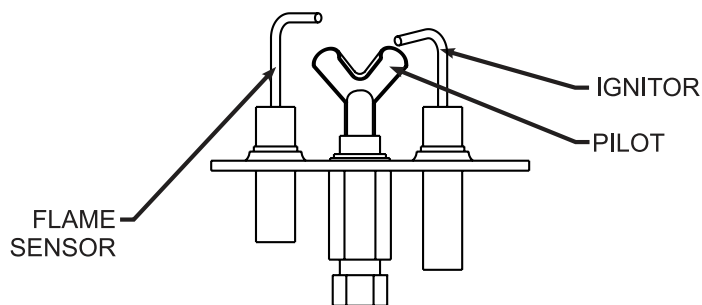

GAS SHUT-OFF VALVE

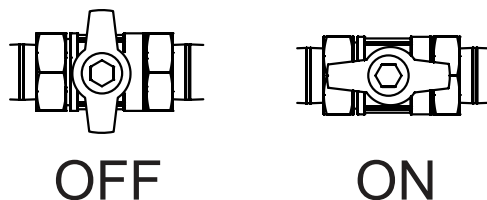

TO TURN OFF GAS TO APPLIANCE

1. Turn off all electric power to the appliance if service is to be performed (if applicable).
2. Locate On/Off gas shut-off and turn clockwise to  **OFF**. Do not force.

4. Operating Instructions



FIRE HAZARD

Can cause severe injury or death. The receiver causes ignition of the fireplace. The fireplace can turn on suddenly. Keep away from the fireplace burner when operating the remote system or activating manual bypass of the remote system.

Turn off the main gas supply and electrical supply to the fireplace during installation and maintenance of the receiver device.



PROPERTY DAMAGE HAZARD.

Excessive heat can cause property damage. The fireplace can stay lit for many hours. Turn off the fireplace if it is not going to be attended for any length of time. Always place the transmitter where children can not reach it.

DO NOT USE a screwdriver or other metallic object to remove the batteries from the battery box or the handset! This could cause a short circuit

FIRE OR EXPLOSION HAZARD.

Can cause property damage, severe injury or death. Do not attempt to take apart the gas control or to clean it. Improper assembly and cleaning can cause unreliable operation.

NOTICE: This control system includes a battery back-up pack that allows the fireplace to operate in the event of a power outage.

NOTICE: The variable halogen lighting and blower features will not operate during a power outage.

NOTICE: Replace all batteries at least once each year, preferably before at the beginning of the season.

4.1 Noise coming from the fireplace

It is normal for fireplaces fabricated of steel to give off some expansion and/or contraction noise during the start up or cool down cycle. Similar noises are found with your furnace heat exchanger or car engine.

It is also normal for the fan to make some noise when it comes on. This noise can be reduced somewhat by turning down the speed of the fan with the variable speed control. Be aware, however, that this will reduce the volume of heated air circulated into the room by the fan.

4.2 First operation

Burn your fireplace for at least one hour the first time you use it. Place the blower in the OFF position during this time.

It is normal for your gas fireplace to give off some odor the first time it is burned. This is due to the curing of the paint and oil from the manufacturing process. Please ensure that your room is well ventilated - open a window.

4.3 Controls

There are two ways to control your fireplace

1- With a wall Switch as shown in the following picture, the fireplace can be turned On (Hi only and OFF with the wall switch. (See installation instruction for its installation) The fireplace flame ON/OFF is the only function that will operate; no flame adjustment, light or blower will work when using the wall switch. The wall control switch should be turned OFF when the fireplace is not being used for extended periods of time.

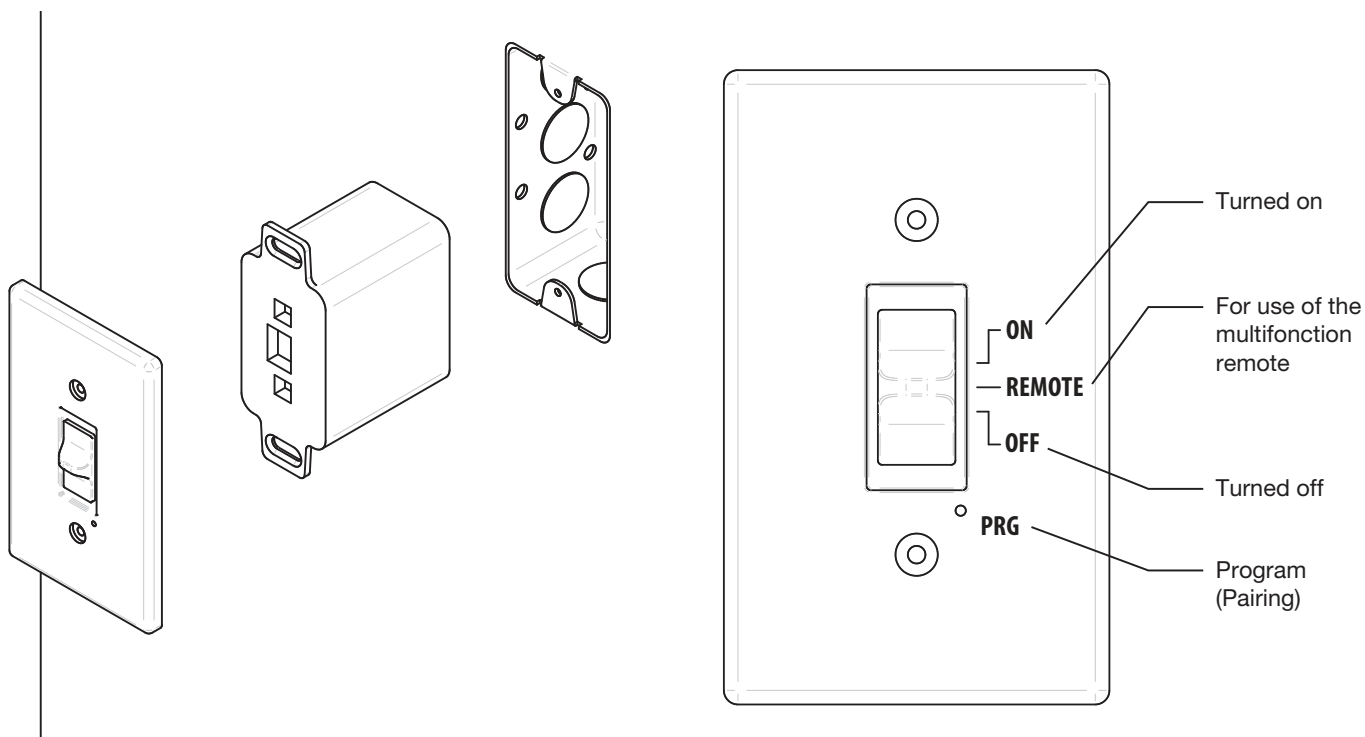

2- With a multifunction thermostatic Remote (Transmitter)

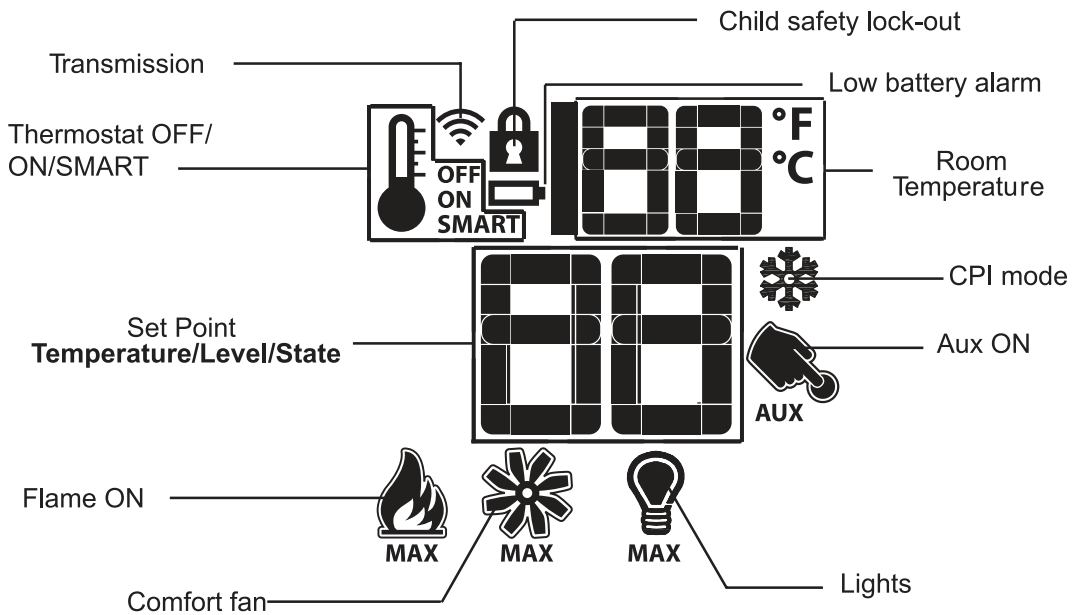
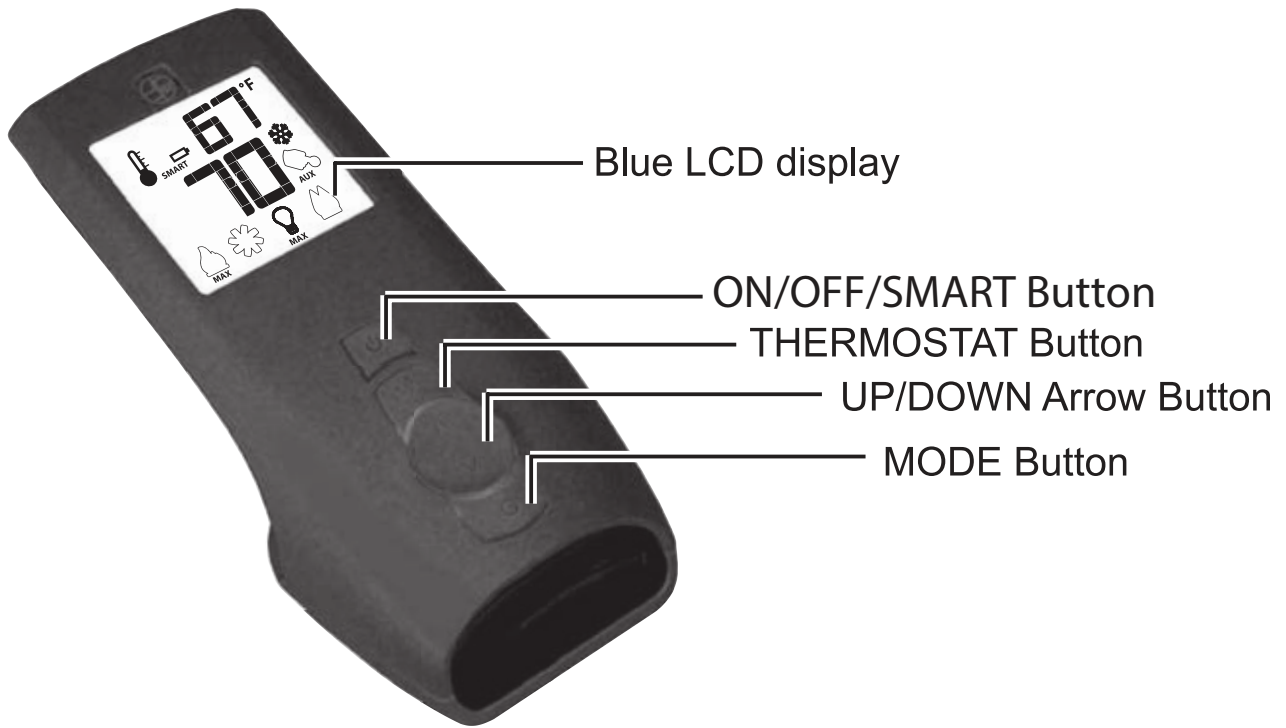

Technical Data - Remote Control

Supply voltage	4.5 V (three 1.5 V AAA batteries)
Ambient temp. ratings	0-50°C (32 - 122°F)
Radio frequency	315 MHz

4.3.1 Pairing the remote

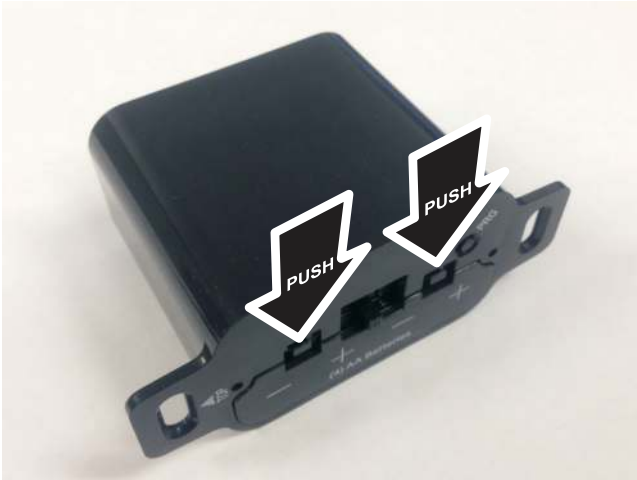

1. Remove cover on the wall mounted battery back-up holder. Install the four AA batteries into the holder then reinstall the cover.
2. Install three AAA batteries into the battery bay located on the base of the remote

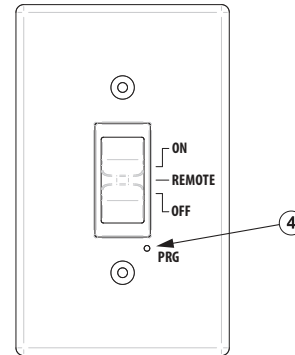
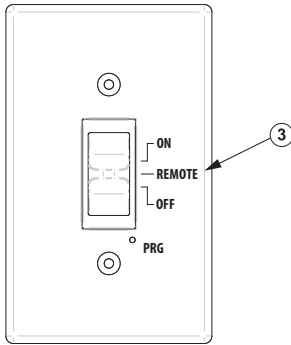

3. Set the wall remote slide switch to the REMOTE position.
4. Press and release the PRG button on the wall control with a paper clip and the IFC module will beep three times to indicate the IFC module is ready to synchronize with the transmitter within ten seconds.

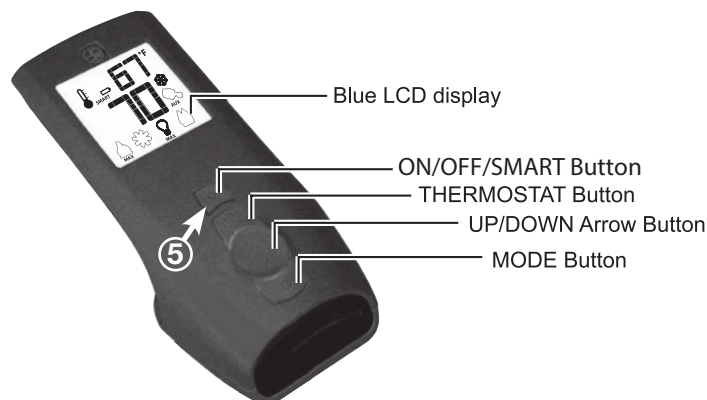

5. With the batteries already installed in the transmitter, push the ON/OFF button. The receiver will beep four times to indicate the transmitter's command is accepted and sets to the particular code of that transmitter. The system is now initialized.

4.3.2 Temperature Display

With the transmitter in the OFF position, press the thermostat button and the mode button at the same time. Look at the LCD screen on the transmitter to verify that a °C or °F is visible to the right of the room temperature display.

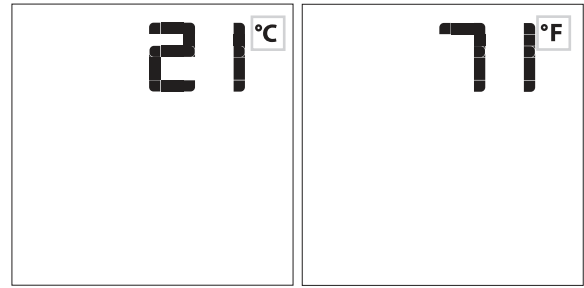

4.3.3 Turn On the Fireplace

The system is on OFF mode if the wall remote is on mode OFF or if the wall remote is on mode REMOTE and the transmitter screen display only the temperature or the temperature and a snowflake as show by the image on the right

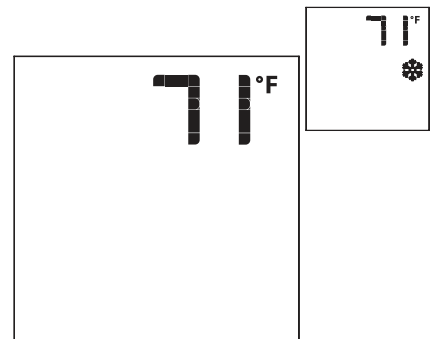
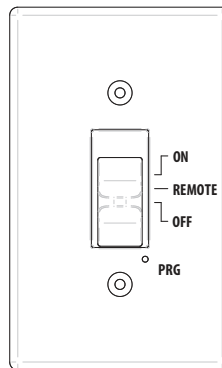

To turn the system on, make sure the wall remote is on mode REMOTE, then press the ON/OFF button on the transmitter. The transmitter display will show some other active icons on the screen. At the same time the receiver will activate the fireplace. A single beep from the receiver will confirm reception of the command.

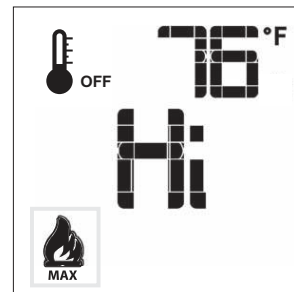
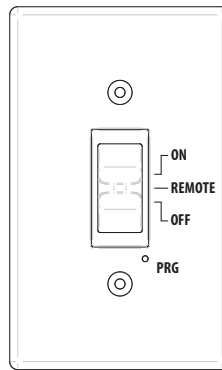

4.3.4 Turn OFF the Fireplace

With the system ON, press the ON/OFF button on the transmitter. The transmitter LCD display will only show the room temperature. At the same time, the receiver will turn off the fireplace. A single beep from the receiver confirms reception of the command.

4.3.5 Remote Flame Control

The Proflame has six flame levels. With the system on, the flame icon selected with the mode button so the flame is black and with as the image bellow, pressing the down arrow button once will reduce the flame height by one step until the flame is turned off.

The up arrow button will increase the flame height each time it is pressed. If the up arrow button is pressed while the system is on but the flame is off, the flame will come on in the high position. A single beep will confirm reception of the command.



Flame OFF

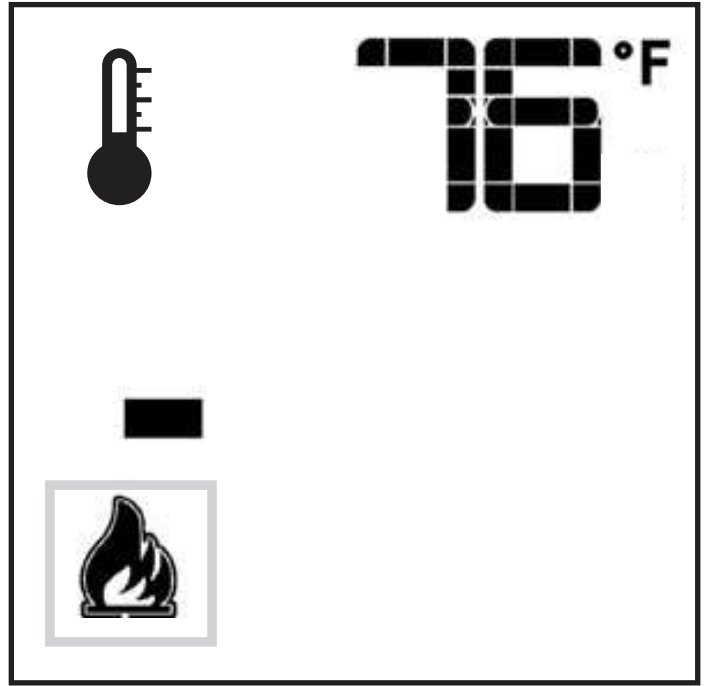

Flame Level 1

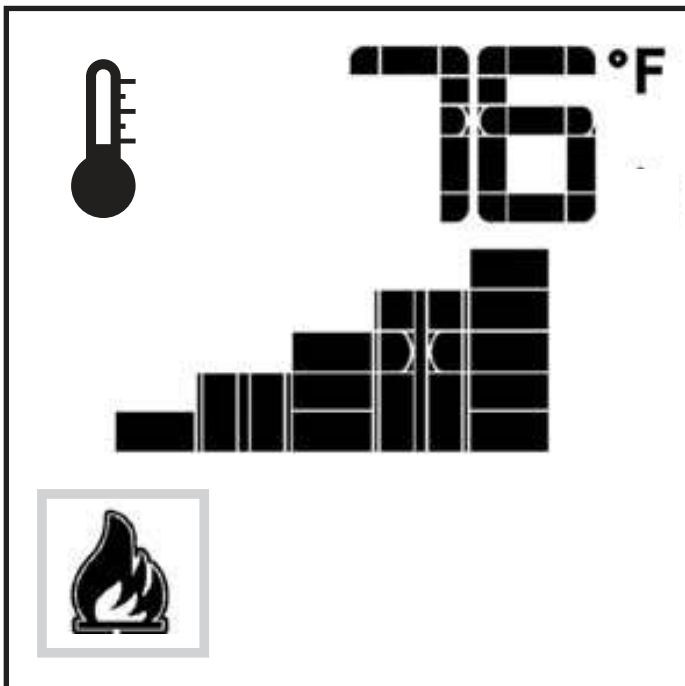

Flame Level 5

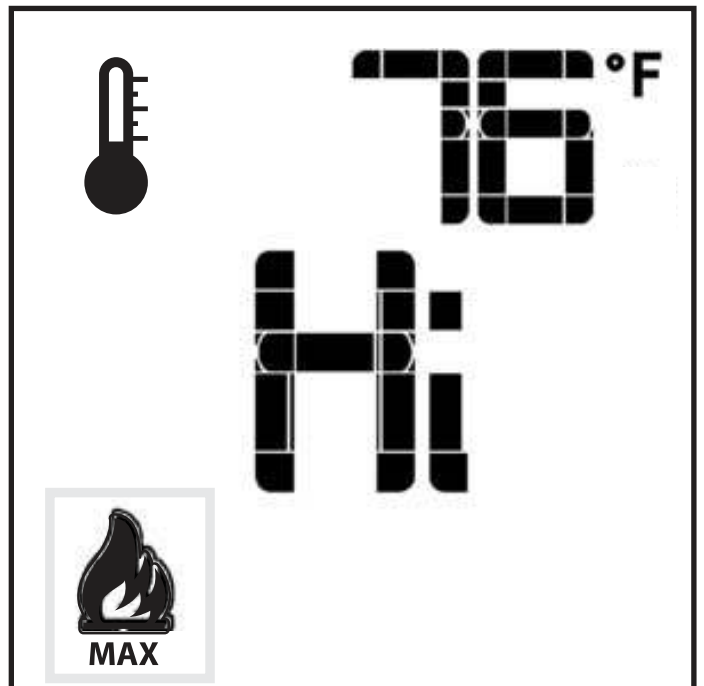

Flame Level Maximum

4.3.6 Disabling Thermostat Feature

With all the (3) AAA type batteries installed:

Take out one AAA battery.

While re-inserting the AAA battery, push and hold down the thermostat button. This will disable the thermostat feature on the transmitter.

The transmitter will show number ranging from 5 to 35. Those number will represent the flame intensity.

4.3.7 Room Thermostat

The remote control can operate as a room thermostat. The thermostat can be set to a desired temperature to control the comfort level in a room. To activate this function, press the THERMOSTAT button (see «4.3 Controls»). The LCD display on the transmitter will change to show that the room thermostat is ON and the set temperature is now displayed.

To adjust the set temperature, press the up or down arrow buttons until the desired set temperature is displayed on the LCD screen of the transmitter.

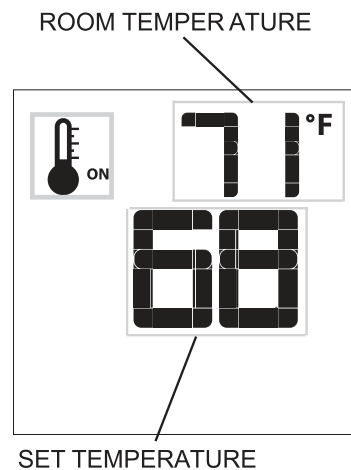

4.3.8 Smart Thermostat

The smart thermostat function adjusts the flame height in accordance to the difference between the set point temperature and the actual room temperature. As the room temperature gets closer to the set point the smart function will modulate the flame down.

To activate this function, press the thermostat button until the word SMART appears to the right of the temperature bulb graphic. (see «4.3 Controls»). To adjust the set temperature, press the up or down arrow buttons until the desired set temperature is displayed on the LCD screen of the transmitter.

Note: When Smart Thermostat is activated, manual flame height adjustment is disabled.

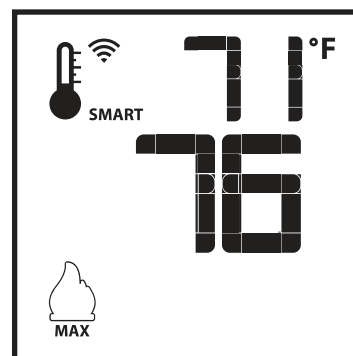

4.3.9 Blower Control

The speed of the blower can be controlled by the proflame system. The blower speed can be adjusted through six speeds. To activate this function, use the MODE button (see «4.3 Controls») to index the blower control icon. Use the UP/DOWN arrow buttons to turn on, off or adjust the blower speed. A single beep will confirm reception of the command.

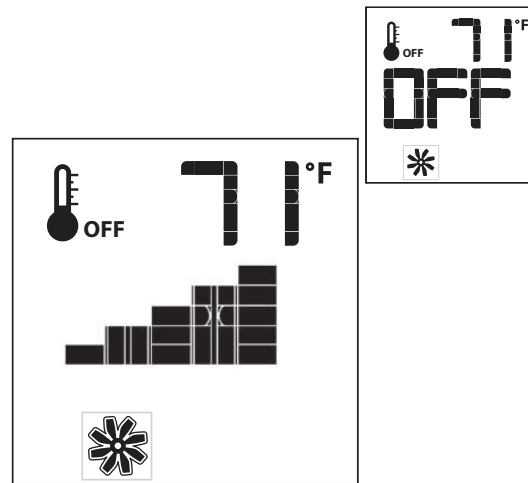

4.3.10 Remote Light Control

If the fireplace is equipped with variable halogen lights, the intensity of the lights can be controlled by the proflame system. The light has five levels of intensity, plus off. To activate this function, use the MODE button (see «4.3 Controls») to index the light control icon. Use the up/down arrow buttons to turn On/Off, or adjust the light intensity level. A single beep will confirm reception of the command.

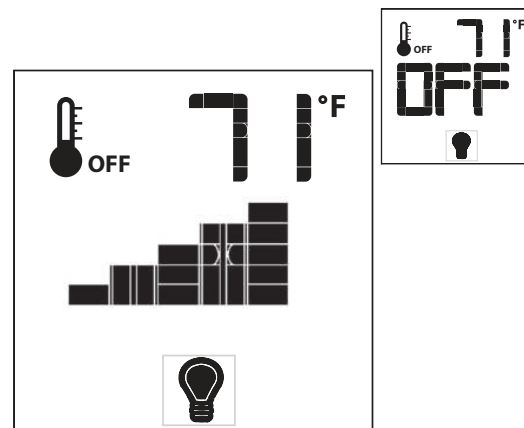

4.3.11 Pilot Selection

With the system in OFF position press the MODE Button to index to the CPI (Continuous pilot) mode icon. Pressing the up arrow button will activate de CPI. Pressing the down arrow button will return to IPI (Intermittent pilot). A single beep will confirm the reception of the command.

Note: In CPI mode, the pilot will shut off after 7 days if the fireplace has not been lighted once during this period.

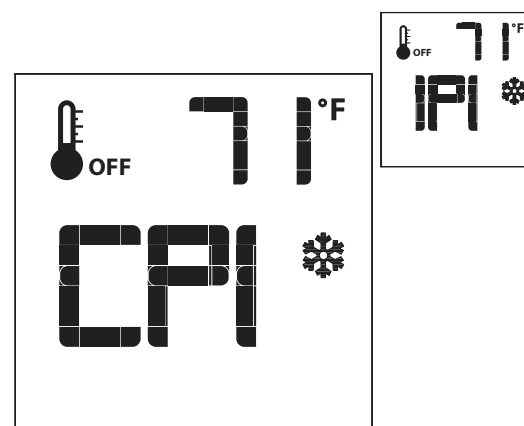

4.3.12 Button Lock

This function will lock the buttons to avoid unsupervised operation. To activate this function, press the MODE and UP buttons at the same time. To deactivate this function, press the MODE and UP buttons at the same time.

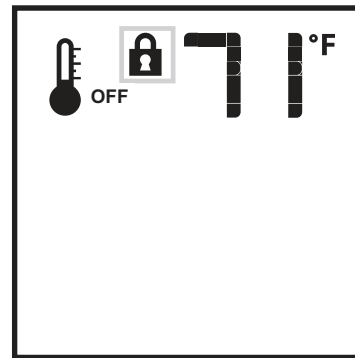

4.3.13 Low Battery Power Detection

The life span of the remote control batteries depends on various factors: quality of the batteries used, the number of ignitions of the fireplace, the number of changes to the room thermostat set point, etc. When the transmitter batteries are low, an icon will appear on the LCD display of the transmitter before all battery power is lost. When the batteries are replaced this icon will disappear.

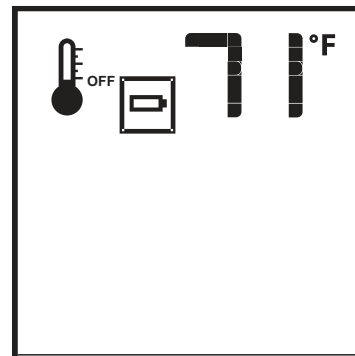

4.3.14 Battery Backup Operation

Install batteries (Pairing the remote step one, [«Pairing the remote», page 17](#)) In case of power loss, the fireplace will switch to battery mode automatically. The fireplace will operate normally without the blower or light control when in battery mode.

4.3.15 Low Battery Detection

When the backup batteries are low, a double-beep will be emitted when the module receives an ON/OFF command. No commands will be accepted until the batteries are replaced or the A/C power is restored.

4.3.16 Lockout State Definition

A lockout state is reached when an ignition error occurs. The lockout state will remain set in memory as long as the power supplies are applied.

This could mean both an anomalous flame detection or too many unsuccessful ignition tries.

This state is a safe condition for the fireplace and is entered automatically by the IFC board.

When the IFC board gets into lockout state:

1. both the pilot and the main burner solenoids in the gas valve are de-energized;
2. a diagnostic code is sent through the diagnostic red LED.
3. the IFC board will ignore any burner ignition command and remain in the OFF state unless the unlock command sequence is met.

The causes of lockout must be investigated under safe conditions by the user and/or the service personnel.

To reset the IFC from a lockout state, perform the following procedure:

- Turn the system power supplies (to the wall control or remote control) OFF for two or three seconds and then restoring a power supply back on.

The return of the system to normal operation must be checked under safe conditions by the user and/or service personnel.

MAINTENANCE AND SERVICE

5. Service call

- All correspondence should refer to complete Model Number, Serial Number and type of gas.

6. *Invisimesh* Barrier and glass door removal

CAUTION

The *Invisimesh* barrier must be handled with care. It is made as invisible as possible. A slight deformation could impair its invisibility properties. Avoid putting pressure on the mesh and make sur the screen weight is never supported by the mesh.

1. Lift the barrier up approximately 1/4-in with one hand under the lower barrier frame edge to disengage the lower flange

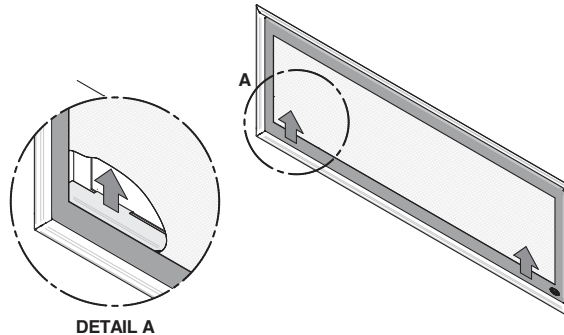

2. Grasp the top of the barrier and pull forward to disengage it. Remove the barrier by pulling straight forward.

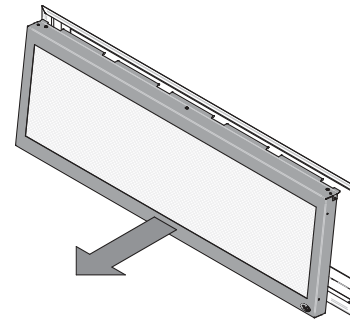

CAUTION



The glass door is wide and heavy and can be difficult to install or remove by a single person. It is recommended that two people remove the glass door.

CAUTION



Sharp objects. Gloves are strongly recommended.

3. Locate the glass door tool (secured to the top of the fireplace for shipping). Use the tool as a lever to release the bottom of the glass door as shown.

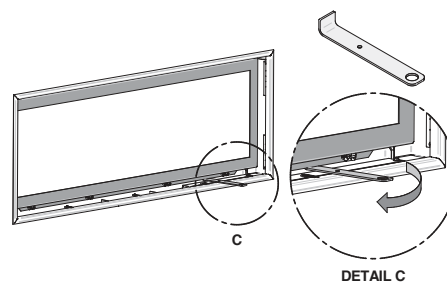

Notice: The glass door is secured to the top of the firebox with tabs that allow the glass door to pivot outward at the bottom. The bottom of the door frame engages into the four bullet type retainers.

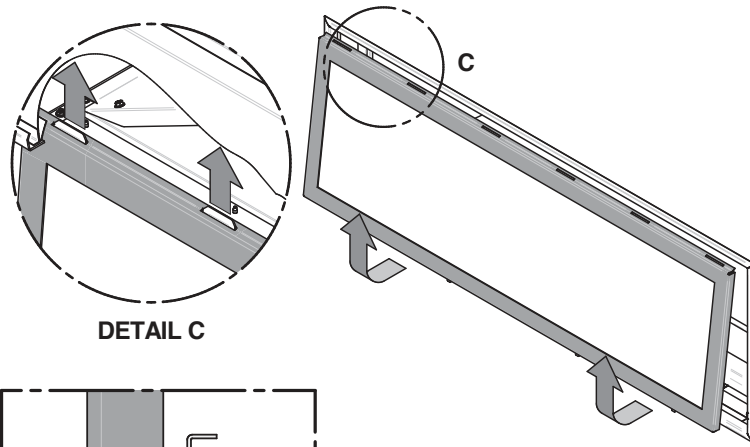

A «click» will be heard as the glass door is properly latched.

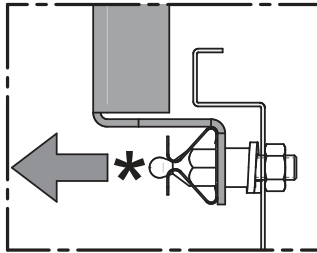

6.1 Glass cleaning

Clean the glass before use and two or three times each heating season. During start-up condensation (which is normal) forms on the inside of the glass and causes lint, dust and other airborne particles to cling to the glass surface. Also initial paint curing may deposit a slight film on the glass. Use a non-abrasive household cleaner and warm water (we recommend gas fireplace glass cleaner).

7. General

CAUTION	
	If any of the original wire supplied with this unit must be replaced, it must be replaced with 18 GA. 150°C wire or its equivalent.

IMPORTANT: Turn off gas before servicing fireplace. Have a qualified service person perform these check-ups once a year preferably before the using of the fireplace.

- Clean burner and control compartment
- Keep the control compartment and burner area clean by vacuuming or brushing at least twice a year.

Do not disassemble the gas control; it contains non-replaceable components. Attempted disassembly or repair can damage the control. Exactly follow the warnings and the lighting instructions.

- The gas control must be replaced if it has been flooded with water. Call a qualified service technician.
- The gas control is a safety device. It must be replaced in case of any physical damage such as bent terminals, missing parts, stripped threads, or evidence of exposure to excessive heat.

7.1 Fireplace cleaning

Cleaning Procedure

1. Turn off fireplace.
2. Remove the barrier screen and glass door assembly.
See [«Invisimesh Barrier and glass door removal», page 24](#).
3. Remove decorative media (a clean portable shop-vac is recommended).
Use gloves to avoid touching the bulb with bare hands.
4. Vacuum burner cover and burner screen areas. The control module located in the bottom front corner can also be vacuumed off.
5. Replace decorative media.
6. Reinstall the glass door and barrier screen.
7. Ignite fireplace. See [«3. Lighting Instructions»](#)
8. If flame appears abnormal, call a service person.

- Check Vent System

The fireplace and venting system should be inspected before initial use and at least annually by a qualified service person. Inspect the external vent cap on a regular basis to make sure that no debris is interfering with the air flow.

7.2 Inspection

7.2.1 Home Owner

- This fireplace must be installed and serviced by your dealer or a qualified service technician. Other than cleaning the glass and replacing the light bulbs, there are no user-serviceable components.
- Keep the area around the fireplace clean and free of debris. This fireplace requires an unimpeded flow of air to circulate warm air. Do not place objects on or around the fireplace that may restrict air flow.
- Keep the area around the fireplace free of combustible materials – including drapery, upholstered furniture, paper, boxes, and clothing. Never hang stockings or cards above the fireplace.
- Never operate the fireplace with the glass front removed or damaged. Any part removed for cleaning or servicing must be replaced prior to operating the fireplace.
- The fireplace gets hot during operation and may remain hot for an hour after use. When operated by thermostat, the fireplace will turn on and off automatically.
- This fireplace may become hot enough to burn skin and ignite clothing after prolonged contact. To prevent injury, alert people in your home – especially children – to the hazards of high surface temperatures and warn them to stay away from the fireplace.
- Supervise children whenever the fireplace is hot. Young children and others may be susceptible to accidental contact burns. Have your dealer install a physical barrier if there are at-risk individuals in your home. To restrict access to a fireplace or stove, install an adjustable safety gate to keep toddlers, young children, and other at-risk individuals out of the room and away from hot surfaces.
- The vent cap, located on the outside of your home, will also become very hot. Alert everyone, adults and children, to stay clear and avoid touching the vent cap. Keep the area around the vent cap clear of combustibles, including shrubs and trees.

- Do not use this fireplace if any part has been underwater. Have a qualified technician inspect the fireplace and replace any part that has been underwater.
- In the event of a natural disaster (tornado, earthquake, fire, etc.) have a qualified technician inspect the fireplace for damage or potential gas leaks. Repair or replace any damaged components before operating this fireplace.
- Never burn solid fuels such as wood, coal, paper or cardboard in this fireplace.

7.2.2 Installer

Maintenance Precautions

- Installation and repair should be done by a qualified service person. The fireplace should be inspected before use and at least annually by a qualified service person. More frequent cleaning might be required due to excessive lint from carpeting, bedding material, etc.
- Keep burner and control compartment clean.
- Examine venting system periodically and replace damaged parts.
- Make a periodic visual check of pilot and burners. Clean and replace damaged parts.

Damaged Fireplace

- Do not use this fireplace if any part has been under water. Immediately call a qualified service technician to inspect the fireplace and to replace any part of the control system and any gas control which has been under water.
- In the event of a natural disaster (tornado, earthquake, fire, etc.) have a qualified technician inspect the fireplace for damage or potential gas leaks. Repair or replace any damaged components before operating this fireplace.

Annual Inspection

- Have the fireplace inspected annually before use.
- More frequent inspection and cleaning may be required if the fireplace is installed in an area exposed to pet hair or dust, or to excessive lint from new carpeting or bedding materials.
- During the annual checkup, the technician will:
 - Inspect the pilot (flame safety system) and burner(s) for proper operation and replace any damaged parts
 - Test and measure the flame failure response time of the flame safety system. It must de-energize the safety shut-off in no more than 30 seconds.
 - Vacuum and clean any foreign debris in the firebox that is not supposed to be there.

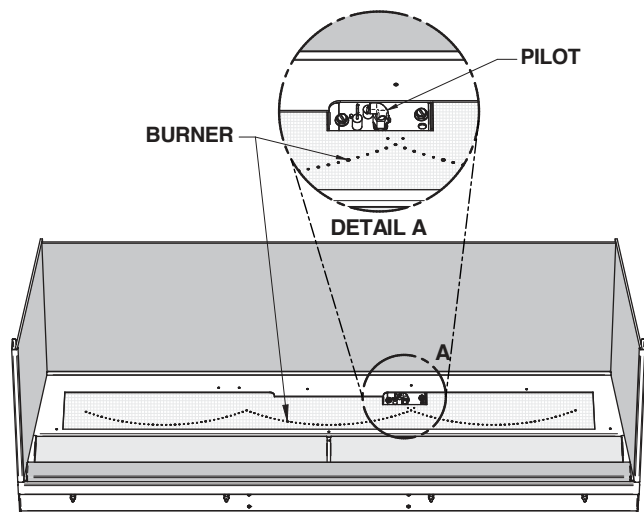

- Inspect and ensure that the lighting of the main burner occurs within 4 seconds of the gas valve opening. Visual inspection should match the information illustrated in the manual. Inspect primary air openings for blockage.
 - Check the glass and gasket for proper seal.
 - Clean glass with a suitable fireplace glass cleaner. Abrasive cleaners must not be used. Be careful not to scratch the glass when cleaning.
 - Check all latches or other door retention components for proper operation, tension, and relief mechanisms are free from obstructions.
 - Check the barrier screen for fit and structural integrity.
 - Inspect the log set (if applicable) and decorative media (if applicable) for debris or damage.
 - Freshen up the glowing embers if applicable.
 - Replace batteries in the remote transmitter and receiver if applicable.
 - Inspect the venting and vent termination cap for damage, corrosion, sooting, or obstruction and correct if present.
 - Check all accessible gas-carrying tubes, connections, pipes and other components for leaks.
- In addition, clean and inspect the fireplace following any remodeling work in your home.

7.3 Light Bulbs replacement

BULB TYPE: 120V 35W G 6.35MM BASE

CAUTION



Turn off all power to the fireplace prior to changing bulbs or servicing the controls.

CAUTION



Sharp Edges! Use gloves and eye protection when servicing the fireplace controls. Use gloves to avoid touching the bulb with bare hands.

1. Remove the barrier and the glass door assemblies.

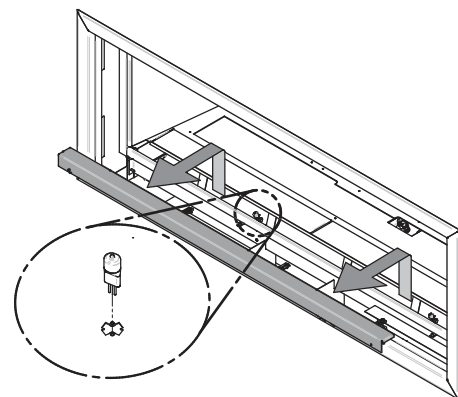
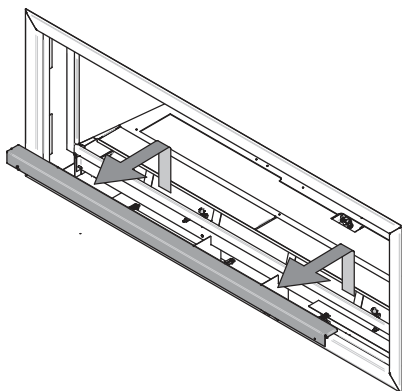

2. Lift the light access cover up and out of the firebox.

3. Remove the bulb(s) to be replaced.

7.4 Gas Valve

CAUTION



Sharp Edges!
Use gloves and eye protection when servicing the fireplace controls.

Notice: Always turn off gas and electrical supply to the fireplace before servicing the controls.

1. Remove the barrier screen and glass door assemblies and set them aside in a safe location.
2. It is not necessary to remove decorative glass media from the burner cover or accent glass panels to gain access to the valve compartment.
3. Remove the front light cover. Lift the cover up and out of the fireplace and set aside in a safe location.

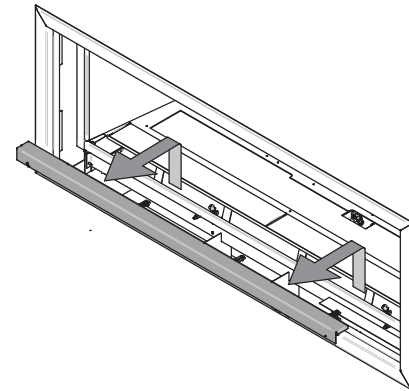

4. Remove the right side liner. Remove the 5/16in hex-head screw at the top rear of the right side panel. Pull forward on the right side liner to release it from the front retainer bracket and set aside in a safe location. (See Liner installation instruction for more information)
5. Remove the twelve 5/16-in hex-head screws that secure the access cover plate on the right side of the firebox.

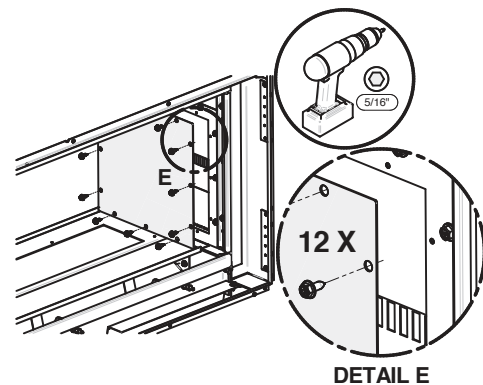

6. The gas valve is now accessible for checking inlet and outlet gas pressures, flex line connections, and wiring to the valve.

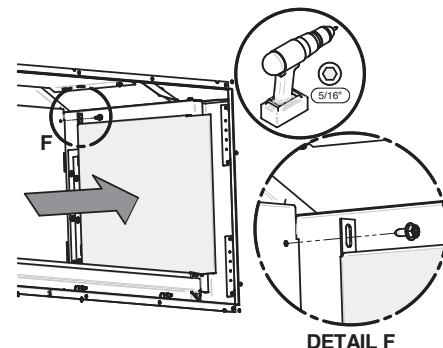

- Inlet and outlet gas test ports.

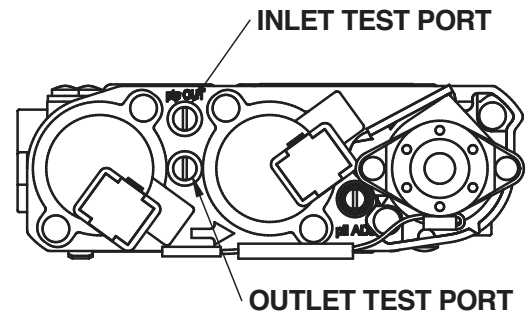

- Replace the gas valve by removing the two 5/16 in hex-head screws on top of the gas control bracket. The gas valve and bracket can be lifted up to gain access to the flex line connections.

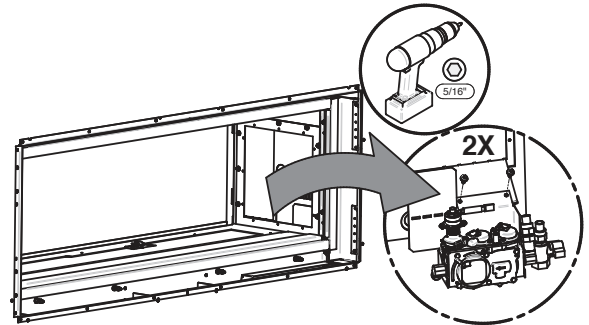

7.4.1 Accessing the Control Module

Always turn off gas and electrical supply to the fireplace before servicing the controls.

- Remove the barrier screen and glass door assemblies, and set them aside in a safe location.
- It is not necessary to remove decorative glass media from the burner cover or accent glass panels to gain access to the control module.

- The control module is in the lower front corner of the fireplace bottom. It is secured to the fireplace with Velcro. The gas control and variable halogen lighting wiring is routed through the lower right side opening to the gas valve and variable halogen lighting wire connections in the firebox. The 120V power cord is routed through the lower right side opening and plugged into the Junction Box receptacle.

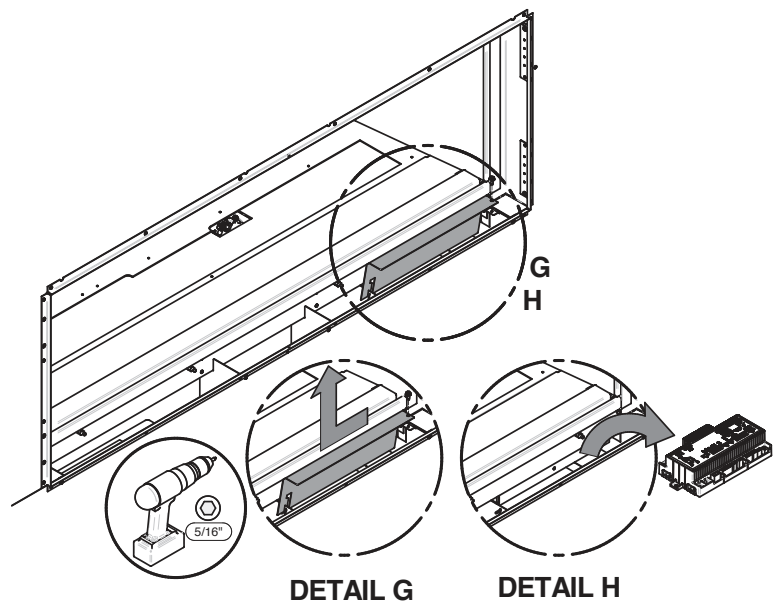

7.5 Maintenance Frequency

Maintenance frequency must be determined individually for each application.

Some considerations are:

- Exposure to water, dirt, chemicals and heat can damage the gas control and shut down the control system.
- Cycling frequency. Fireplaces that may cycle 50 times daily or more should be checked monthly.
- Intermittent use. Fireplaces that are used seasonally should be checked before shutdown and again before the next use.
- Dusty, wet or corrosive environment. Because these environments can cause the gas control to deteriorate more rapidly, the system should be checked more often.
- Any control should be replaced if it does not perform properly on checkout or service. In addition, replace any module if it is wet or looks like it has been wet.

7.6 Maintenance venting

Inspect venting system **semi-annually** as follows:

1. Check for corrosion areas of the venting system exposed to the elements. These will appear as rust spots or streaks and, in extreme cases, holes. Damaged components should be replaced immediately.
2. Remove the cap and shine a flashlight down the vent. Remove any bird nests or other foreign material.
3. Check for evidence of excessive condensate, such as water droplets forming in the inner liner and subsequently dripping out at joints. Condensate can cause corrosion of caps, pipe and fittings. It may be caused by having excessive lateral runs, too many elbows and exterior portions of the system being exposed to cold weather.
4. Inspect joints to verify that no pipe sections or fittings have been disturbed and, consequently, loosened. Also, check mechanical supports, such as wall straps or plumbers tape for rigidity.

A removable panel or other means must be provided in the enclosure for visual inspection of the flue connection.

NOTICE: This also pertains to vertical vent systems installed on the outside of the building.

Venting termination shall not be recessed into a wall or siding.

Slide the vertical vent cap over the ends of the vent pipe and secure.

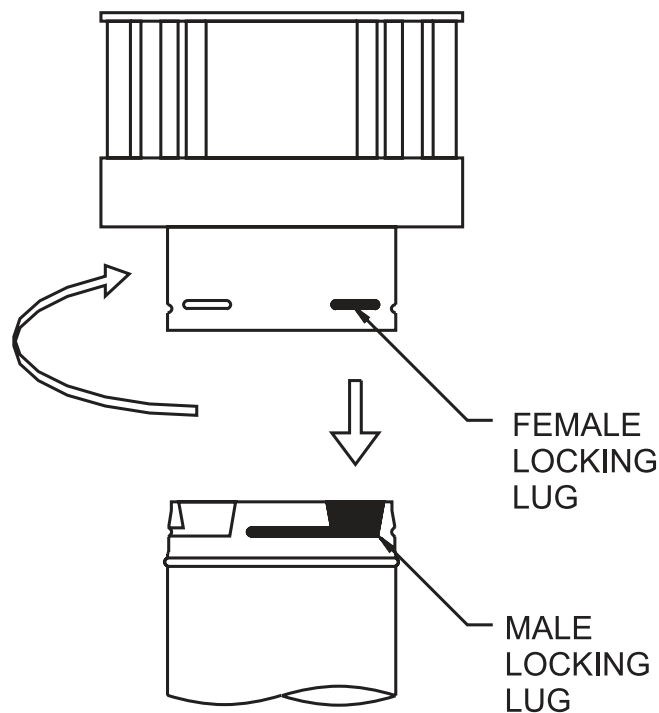

Slide the vertical vent cap over the ends of the vent pipe and secure

7.7 Control System Troubleshooting

PROBLEM OBSERVED	POSSIBLE CAUSE	CORRECTIVE MEASURE
Gas odor during setup	Gas Leak	WHAT TO DO IF YOU SMELL GAS Do not try to light any appliance. Do not touch any electrical switch; do not use any phone in your building. Leave the building immediately. Immediately call your gas supplier from a neighbor's phone. Follow the gas supplier's instructions. If you cannot reach your gas supplier, call the fire department.
Gas odor before first ignition	Gas Leak	
Fireplace is "on" but no flame and pilot is not trying to light	Gas Line Valve turned "off"	Turn shutoff valve to "open" position
	Control module in "lockout"	Turn fireplace "off" and then back "on"
Pilot continues to spark when pilot is lit.	Not enough gas to pilot	Wait for pilot flame to strengthen
	Low Gas Pressure	Check pressures.
	Pilot igniter/sensor is dirty	Clean pilot.
	Pilot not grounded well	Check ground connections
	Draft in firebox	Vent restrictor not installed
	Pilot sensor has been bent	Replace pilot
Pilot will not ignite, or will not stay lit	Pilot igniter/sensor is dirty	Clean flame sensor and pilot igniter.
	Pilot not grounded well	Check ground connections
	Sensor Wire loose	Check sensor wire terminals
	Gas pressure incorrect	Adjust gas pressure
	Pilot Gas Line bent or kinked	Replace pilot tube
	Faulty pilot, Sensor bent	Replace Pilot
	Faulty valve	Replace Valve
Burner takes too long to fully light	Low gas pressure	Check gas supply pressure
	Clogged or dirty carryover/ burner ports	Clean ports
	Blocked orifice	Check orifice opening
	Faulty valve	Replace valve
Burner does not light but pilot remains on	Low gas pressure	Check gas supply pressure
	Clogged or dirty burner ports	Clean burner ports
	Blocked orifice	Check orifice opening
	Loose wire connections	Check valve/control module connections
	Faulty pilot	Replace pilot
	Faulty valve	Replace valve

PROBLEM OBSERVED	POSSIBLE CAUSE	CORRECTIVE MEASURE
Burner lights but does not stay lit while pilot remains on	Low gas pressure	Check gas supply pressure
	Loose sensor wire	Check wire connection
	Faulty valve	Replace valve
	Faulty pilot or thermocouple	Replace Safety pilot
	Clogged or dirty burner ports	Clean burner ports
	(For fireplace equipped with optional thermostat or thermostat remote) Room temperature is higher than thermostat setting	Move (optional) remote away from fireplace
	(Optional) Remote control batteries failing	Replace batteries in remote transmitter and receiver
Burner & pilot light but will not stay lit	Flame sensor dirty	Clean pilot sensor
	Low gas pressure	Check gas supply pressure
	Not enough fresh air for pilot	Open door or window - ventilate
	Clogged or dirty burner ports	Clean burner ports
	(For fireplace equipped with optional thermostat or thermostat remote) Room temperature is higher than thermostat setting	Move (optional) remote away from fireplace
	(Optional) Remote control batteries failing	Replace batteries in remote transmitter and receiver
	Faulty pilot or thermocouple	Replace pilot
Incorrect burner flame	Incorrect gas supply or pressure	Check gas supply pressure
	Blocked orifice	Check orifice opening
	Clogged or dirty burner ports	Clean burner ports
	Faulty valve	Replace valve
	High altitude	Adjust orifice size for altitude
Backfire of burner	Blocked orifice	Check orifice opening
	Clogged or dirty burner ports	Clean burner ports
	Low gas pressure	Check gas supply pressure
Fireplace produces unwanted odors	Vapors from paint, hairspray, glue, etc.	Ventilate room until odor stops. Do not use paint, hairspray, glue, etc around fireplace
	Initial burn-off of manufacturing chemicals	Ventilate room until odor stops
Whistle noise from fireplace	Check gas pressure	Adjust gas pressure to recommended setting.
	Air in gas line	Bleed lines
	Control knob not in fully open position	Open control knob to full position
	Spiral gas flex line pinched or too small diameter line	Straighten flex line where pinched or replace gas feed line with larger diameter

8. Parts View and Parts List

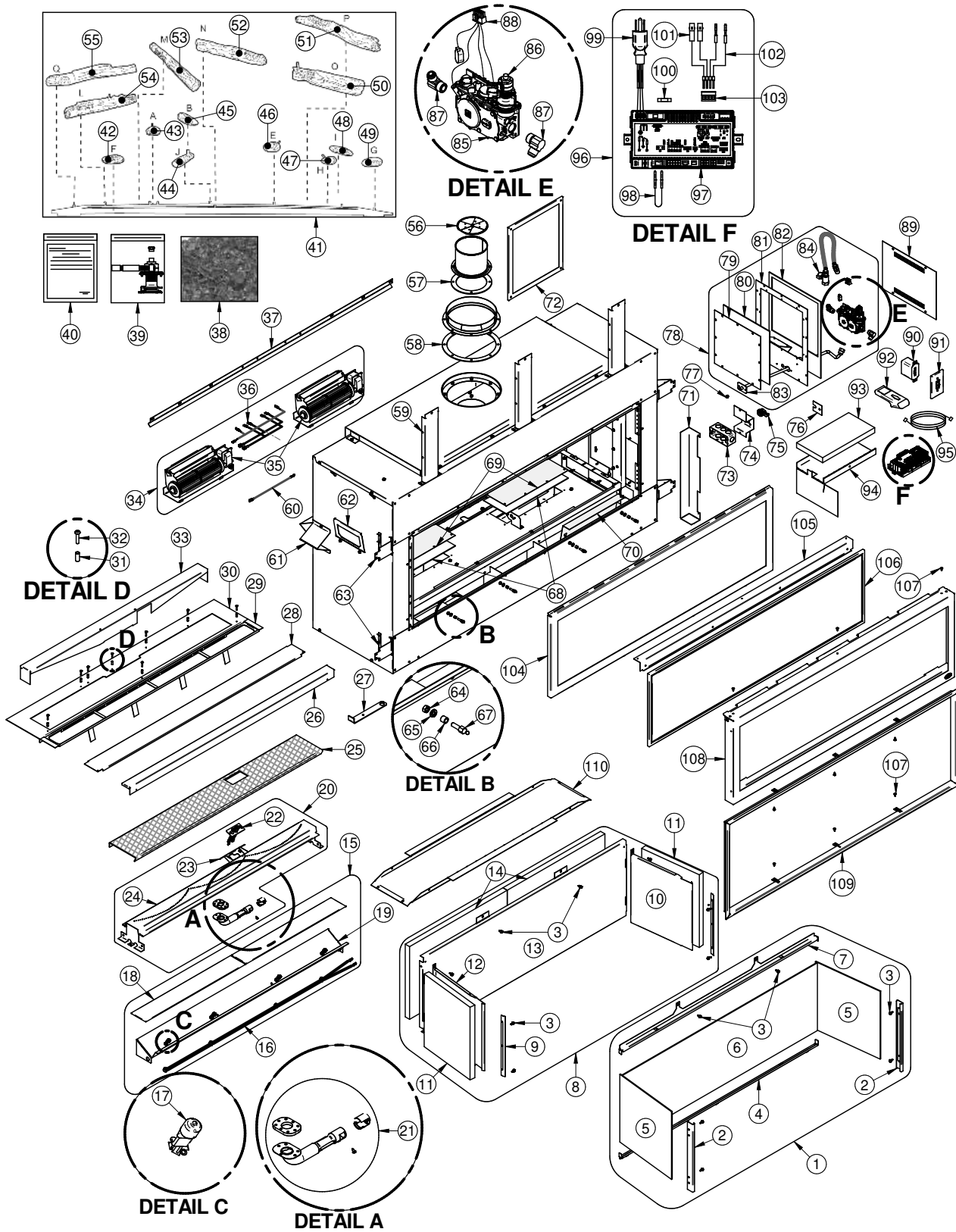

⚠ WARNING

Failure to position the parts in accordance with these diagrams or failure to use only parts specifically approved with this fireplace may result in property damage or personal injury.

ENGLISH

PARTS, PART NUMBERS AND AVAILABILITY ARE SUBJECT TO CHANGE WITHOUT NOTICE.

PARTS IDENTIFIED AS STOCKED WILL BE DELIVERED WITHIN 2 TO 5 BUSINESS DAYS FOR MOST DELIVERY DESTINATIONS.

PARTS NOT IDENTIFIED AS STOCKED WILL BE DELIVERED WITHIN A 2 TO 4 WEEK PERIOD.

PARTS IDENTIFIED AS 'SO' ARE SPECIAL ORDER AND CAN TAKE UP TO 90 DAYS FOR DELIVERY.

	Part #	Description	Qty
1	AC04331	BLACK REFLECTIVE GLASS PANELS	1
2	PL71288	SIDE TRIM	2
3	31048	SCREW NO 10 X 1/2 HWH PH TYPE AB BLACK CHROMATE	10
4	PL71287	LOWER REAR TRIM	1
5	23095	BLACK CERAMIC GLASS - 13 1/2"W X 13 1/2"H	2
6	23094	BLACK CERAMIC GLASS - 44 13/16"W X 13 1/2"H	1
7	PL71289	UPPER REAR TRIM	1
8	AC04329	BLACK STEEL PANELS	1
9	PL71034	SIDE PANEL BRACKET	2
10	PL71057	RIGHT LINER PANEL	1
11	21554	14 1/2" X 12" X 1" INSULATION	2
12	PL71056	LEFT LINER PANEL	1
13	PL71055	REAR LINER PANEL	1
14	21543	14 1/2" X 22 1/2" X 1" INSULATION	2
15	AC04336	VARIABLE HALOGEN LIGHTING	1
16	60417	LIGHT SOCKET ASSEMBLY	1
17	44229	35W LIGHT BULB	4
18	PL71008	GLASS - 22 7/8"W X 3 3/8"H	2
19	PL71061	LIGHT BULBS FRAME	1
20	SE71060	BURNER ASSEMBLY	1
21	99999	BUILD TO ORDER	1
22	49703	CONVERTIBLE PILOT ASSEMBLY	1
23	PL71050	PILOT BRACKET	1
24	99999	BUILD TO ORDER	1
25	PL71060	SCREEN BURNER COVER	1
26	PL71037	LIGHT COVER	1
27	PL71045	DOOR LATCH TOOL	1
28	PL71039	SOLID COVER	1
29	PL71054	GLASS SUPPORT	1
30	PL71053	BURNER COVER PLATE	1
31	31151	1/4" OD X 9/16" SPACER	8
32	31150	THREAD CUTTING SCREW #8-32 X 3/4" "F" TYPE PHILLIPS	8
33	PL71028	REAR BAFFLE	1
34	SE71280	BLOWER KIT (2 X 130 CFM 115V-60Hz-50W)	1
35	44239	CROSSFLOW BLOWER SINGLE CAGE 130 CFM 115V-60Hz-50W (CLASS H)	2
36	60415	BLOWERS HARNESS	1
37	PL71020	STIFFENING RAIL	1
38	AC04382	BLACK CRUSHED GLASS MEDIA SET (L48)	1

	Part #	Description	Qty
39	AC04338	LP TO NG CONVERSION KIT	1
40	46139	L48 INSTRUCTION MANUAL	1
40	SE46139	L48 OWNER'S MANUEL KIT	1
41	AC04334	DRIFTWOOD SET AND PEBBLES	1
42	22370	ROCK F - L48 KIT	1
43	22369	ROCK A - L48 KIT	1
44	22371	ROCK J - L48 KIT	1
45	22365	ROCK B - L48 KIT	1
46	22368	ROCK E - L48 KIT	1
47	22367	ROCK H - L48 KIT	1
48	22364	ROCK I - L48 KIT	1
49	22366	ROCK G - L48 KIT	1
50	22362	LOG O - L48 KIT	1
51	22358	LOG P - L48 KIT	1
52	22363	LOG N - L48 KIT	1
53	22361	LOG M - L48 KIT	1
54	22359	LOG L - L48 KIT	1
55	22360	LOG Q - L48 KIT	1
56	SE71242	FLUE RESTRICTOR	1
57	21537	FLUE OUTLET GASKET	1
58	21538	AIR INTAKE FLUE GASKET	1
59	PL71044	MIDDLE MOUNTING BRACKET	3
60	60398	GROUND WIRE	1
61	PL71298	REAR STAND-OFF	2
62	PL71027	CARRYING HANDLE	2
63	PL71052	NAILING TAB	4
64	31133	NUT M6 STAINLESS STEEL	4
65	30216	1/4" LOCK WASHER	4
66	31049	ALUMINIUM SPACER	4
67	31050	SPHERICAL NAIL	4
68	21588	BLOWER SUPPORT GASKET 5.25" X 14.25" X 1/8"	2
69	PL71041	ACCES PLATE	2
70	PL71040	REMOVABLE CONTROL MODULE SHIELD	1
71	PL71036	BLOCK OFF PANEL	1
72	PL71189	BAFFLE SPACER	1
73	44000	ELECTRICAL BOX	1
74	PL71151	CATALYST HOUSING SUPPORT	1
75	60201	CONNECTOR 1 SCREW 3/8" FOR BX WIRE	1
76	PL71032	VALVE ACCESS PLATE	1
77	49689	LPG Orifice #50	1
78	SE71030	VALVE ASSEMBLY WITH ACCESS PLATE	1
79	PL71031	INNER CONTROL COVER	1
80	21541	ACCESS PANNEL GASKET	1
81	PL71030	ACCESS PANEL WITH OPENING	1
82	21542	INNER ACCESS PANNEL GASKET	1

	Part #	Description	Qty
83	49688	3/8 FLEX LINE WITH ORIFICE SUPPORT	1
84	49697	3/8 X 12" FLEX LINE WITH SHUTOFF VALVE	1
85	49691	MODULATING VALVE LPG	1
86	49717	STEPPER MOTOR SIT 886 (LP)	1
87	49177	90 DEG ELBOW 0.375 NPT X 0.375 TUBE	2
88	44219	WIRE HARNESS RECEIVER - PROFLAME 2	1
89	PL71029	OUTER ACCES PANNEL	1
90	44222	BATTERY HOLDER WITH SWITCH	1
91	44223	BATTERY HOLDER COVER PLATE (Proflame Wall mountCoverWhite)	1
92	44216	PROFLAME II TRANSMITTER (0.584.042)	1
93	21540	MODULE INSULATION 1" X 6" X 12"	1
94	PL71004	MODULE HEAT SHIELD	1
95	60400	MODULE WIRE CONNECTOR	1
96	SE49176	MODULE PROFLAME II WITH WIRES	1
97	49176	MODULE PROFLAME II	1
98	60393	JUMPER WIRE	1
99	60395	19" POWER CORD	1
100	44209	FUSE GLASS 3.15A / 250V (5 X 20)	1
101	60399	BLOWER WIRE	1
102	60394	HALOGEN LIGHT KIT WIRE	1
103	44217	4 POSITIONS TERMINAL BLOCK PLUG (MALE PINS)	1
104	SE71058	GLASS DOOR ASSEMBLY	1
105	PL71038	SCREEN FRAME BRACKET	1
106	31071	INVISIMESH SCREEN BARRIER - 49.625 X 14.437	1
107	31054	METAL SCREW #8-18 X 1/2" TRUSS QUADREX BLACK OXYDE PLATED	10
108	99999	BUILD TO ORDER	1
109	AC04333	LARGE BLACK FINISHING TRIM	1
109	AC04332	REGULAR BLACK FINISHING TRIM	1
110	PL71043	BAFFLE	1

NS - Not Shown

APPENDIX 1: ACCESSORIES

The following accessories must be purchased separately. Their installation instructions are included in their kit and can be found on Valcourt website, in the options/Accessories section of this fireplace's page.

Description	Color	Code
-------------	-------	------

REQUIRED ACCESSORIES

Steel Panels¹	Black	AC04329
Reflective Glass Panels¹	Black	AC04331
Regular Finishing Trim²	Black	AC04332
Large Finishing Trim²	Black	AC04333
Driftwood And River Rocks Kit	---	AC04334

OPTIONS

Variable Halogen Lighting	---	AC04336
----------------------------------	-----	---------

¹ The fireplace must have a liner installed prior to operation

² Only one finishing trim is required

VALCOURT LIMITED 10 YEARS WARRANTY

The warranty of the manufacturer extends only to the original consumer purchaser and is not transferable. This warranty covers brand new products only, which have not been altered, modified nor repaired since shipment from factory. Proof of purchase (dated bill of sale), model name and serial number must be supplied when making any warranty claim to your VALCOURT dealer.

This warranty applies to normal residential use only. Damages caused by misuse, abuse, improper installation, lack of maintenance, negligence or accident during transportation are not covered by this warranty.

This warranty does not cover any scratch, corrosion, warping, or discoloration caused by over firing, abrasives or chemical cleaners. Any defect or damage caused with the use of unauthorized parts or others than original parts void this warranty. An authorized qualified technician must perform the installation in accordance with the instructions supplied with this product and all local and national building codes. Any service call related to an improper installation is not covered by this warranty.

The manufacturer may require that defective products be returned or that digital pictures be provided to support the claim. Returned products are to be shipped prepaid to the manufacturer for investigation. If a product is found to be defective, the manufacturer will repair or replace such defect and reasonable transportation fees will be refunded.

The manufacturer at its discretion may decide to repair or replace any part or unit after inspection and investigation of the defect. The manufacturer may, at its discretion, fully discharge all obligations with respect to this warranty by refunding the wholesale price of any warranted but defective parts. The manufacturer shall in no event be responsible for any special, indirect, consequential damages of any nature, which are in excess of the original purchase price of the product.

**Limited Lifetime Warranty (10 years)*

DESCRIPTION	WARRANTY APPLICATION	
	PARTS**	LABOUR***
Combustion chamber, heat exchanger and factory installed glass door.	Lifetime*	5 years
Burner and burner surround.	Lifetime*	2 years
Logs, steel, glass and refractory liner panels (other than by maintenance or servicing).	2 years	N/A
Gas valve, pilot assembly, harnesses, remote and controls (110V or mV), blower.	2 years	1 year
High temperature paint and other finishes (enamel liner excluded) and invisimesh safety screen.	1 year	1 year
Gasket, light bulbs and other consumables.	N/A	N/A
After market replacement parts coverage.	90 days	N/A

***Exclusion refer to statement above.*

****Labour based on predetermined chart.*

Shall your unit or a component be defective, contact immediately your dealer or **VALCOURT** customer service. Prior to your call make sure you have the following information necessary to your warranty claim treatment:

- Your name, address and telephone number.
- Bill of sale and dealer's name.
- Installation configuration.
- Serial number and model name as indicated on the nameplate fixed to the back of your unit.
- Nature of the defect and any relevant information.

Important: Do not ship your unit or defective component to our plant before you have obtained from your VALCOURT dealer, an Authorization Number. Any merchandise shipped to our plant without authorization

Valcourt

This document is available for free download on the manufacturer's website. It is a copyrighted document. Resale is strictly prohibited. The manufacturer may update this document from time to time and cannot be responsible for problems, injuries, or damages arising out of the use of information contained in any document obtained from unauthorized sources.

Stove Builder International inc.
250, rue de Copenhague,
St-Augustin-de-Desmaures (Québec) Canada
G3A 2H3
418-908-8002
www.sbi-international.com
tech@valcourtinc.com