



TITAN

FREE-STANDING DIRECT-VENT GAS STOVE



Unit Illustrated: FDV200SN Free Standing Stove (Natural Gas), LOGC200 Log Set (Cast Split Oak with glowing embers), FDV200RL Refractory Brick Liner.

The Titan Direct Vent model provides sealed combustion where it draws outside air for combustion. This model can be vented either horizontally or vertically.

TITAN PRODUCT SPECIFICATIONS

MODEL	FDV200SN/NE FDV200SNE2	FDV200SLP/LPE FDV200SLPE2
Fuel	Natural	Propane
Input Max	28,500 BTU	26,000 BTU
Input Min	19,500 BTU	20,000 BTU
FE (P.4.1-15)	66.14%/68.56%	67.47%/69.89%

STANDARD FEATURES

- Millivolt and IPI PF1 valve system allows operation during a power failure with Hi-Low heat and flame adjustment
- IPI Proflame II (PF2) models include Remote Control – features flame, fan, thermostat, smart thermostat (WIFI Compatibility: Amazon Alexa, Google Home, Smartphone) and battery backup
- Dual burner system, with realistic flame pattern
- Heat radiating ceramic glass
- Mobile home approved
- Approved for installation in a bedroom or bed sitting room
- Safety Screen Barrier
- Cast Oak Log Set with glowing embers

OPTIONAL FEATURES

Blower (MV/IPI, PF1): Heat activated with variable speed control

Liner: Refractory Brick (3 pieces)

Remote Control (Millivolt): On/Off, Thermostat On/Off, Thermostat On/Off Modulating

Thermostat (MV/PF1): Wall Mount or Programmable

PRODUCT DIMENSIONS

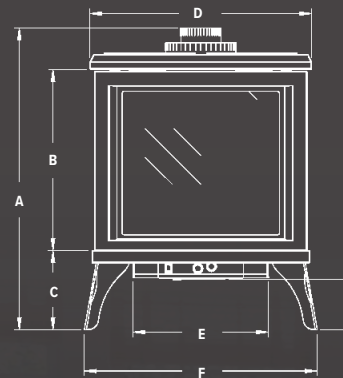

FRONT VIEW

A	30 9/16"
B	18 1/8"
C	8 5/16"
D	22 5/32"
E	13 1/2"
F	23 13/32"
G	5 7/16"

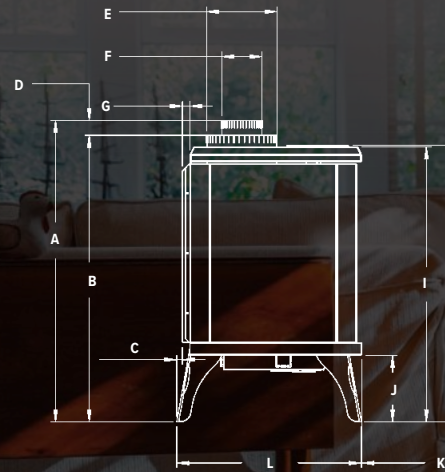

SIDE VIEW

A	30 9/16"
B	29 1/16"
C	5/8"
D	1 1/2"
E	7"
F	4"
G	25/32"
H	28 1/32"
I	27 29/32"
J	7 1/16"
K	7 3/32"
L	18 19/32"

MINIMUM CLEARANCE TO COMBUSTIBLES

6"	from side of unit
3"	from back of unit
3"	from side of unit in corner

ALCOVE INSTALLATION

30"	depth (max)
56"	height (min.)
53"	width (min.)

REMOTE CONTROLS



LOG SET



LOGC200
Cast Split Oak



Canada

ENERGUIDE

Look for the **EnerGuide**
Gas Fireplace Energy
Efficiency Rating in this brochure

Based on CSA P.4.1-15



Marquis Fireplaces maintains a program of continuous testing, refinement and improvements of all its products. Some aspect of units shown here may be changed at any time without notice or obligation.

Certified for USA and Canada to: ANSI Z21.88-2017 / CSA 2.33-2017, CSA 2.17-2017

Note: Components may have to be ordered separately to create a complete unit. Discuss with your local Marquis Dealer for clarification.

Unit Illustrated: FDV200SNE2 Free Standing Direct Vent Gas Stove, LOGC200 Cast Split Oak Log Set with glowing embers, FDV200RL Refractory Brick Liner.



FOR CALIFORNIA RESIDENTS ONLY:
WARNING! This product can expose you to chemicals including Carbon Monoxide, that is an externally vented by-product of fuel consumption, which is [are] known to the State of California to cause birth defects or other reproductive harm. For more information, visit www.P65Warnings.ca.gov.

Crafted entirely in Canada, each Marquis fireplace is built to the highest standards and made to last.



LIMITED LIFETIME WARRANTY

2340 Logan Avenue
Winnipeg, Manitoba, CAN R2R 2V3
Phone: 204.632.1962
Fax: 204.632.1960
marquisfireplaces.net

Printed in Canada
B068 - 09/20