

FP30

FIREPLACE FOR LARGE SPACES

Heat Output Cord Wood **99,000 BTU**

38,500 BTU EPA Test Fuel

EFFICIENCY (LHV)	76.8%
EMISSIONS	2.47 GM/HR.
LOG SIZE (MAX)	18-20 INCHES
FIREBOX SIZE	3.0 CU.FT.
GLASS SIZE	246 SQ.IN.
WEIGHT	626 LB.

Heat larger spaces with the reduced footprint of a wall-mount fireplace: the FP30 offers the best of traditional wood heat, with a contemporary look and all the Pacific Energy extras. Handcrafted with a floating firebox of heavy gauge steel, a high capacity baffle system, and EBT2 extended heat technology, this full-featured unit is designed for a lifetime of efficient, effective heating. And with clean, uncluttered lines and a huge viewing window (that remains clear with Airwash technology) it meets the highest expectations for form and function.

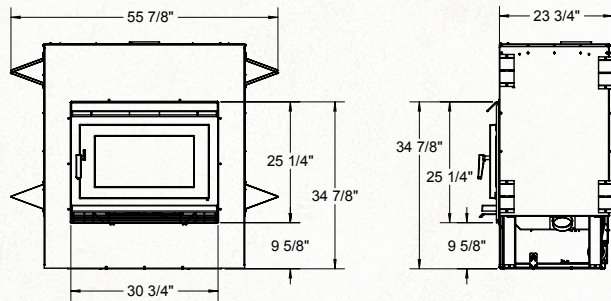

For reference only. Installations should be based on installation manuals. Specifications subject to change.

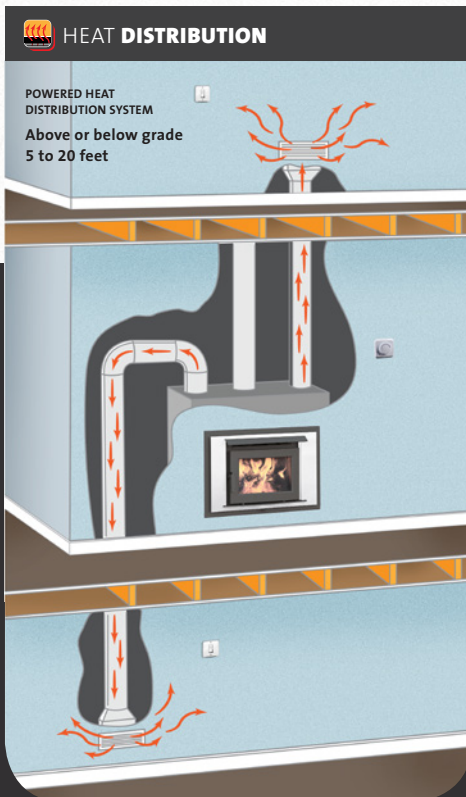

STANDARD FEATURES

- EPA Certified
- Reliable, durable non-catalytic technology
- Air wash system for super clean ceramic glass
- Boost air for easy lighting
- Oversize glass viewing window
- Floating firebox for extended stove life
- 304 Stainless Steel Baffle, insulation cover, rails and flame shield
- High-tech multi-port combustion air injection system
- Extended Burn Technology (EBT2)
- Easy and safe front to back fuel loading
- 3 cubic foot Summit firebox
- 125 cfm temperature actuated blower
- Single-Lever Air Control
- Cast iron door with ash lip
- Cast Iron grills
- Mobile Home Approved
- Requires 6" chimney

PERFORMANCE OPTIONS

EPA Certified Powered Heat Distribution System

