

NEO 1.6 INSERT

WOOD INSERT FOR SMALL TO MEDIUM SPACES

Heat Output Cord Wood

70,000 BTU

33,400 BTU EPA Test Fuel

EFFICIENCY (LHV)	80.9%
EFFICIENCY (B415)	75%
EMISSIONS	3.4 GM/HR.
LOG SIZE (MAX)	16-18 IN.
FIREBOX SIZE	1.6 CU.FT.
GLASS SIZE	131 SQ.IN.
WEIGHT	285 LBS.

Make your smaller existing masonry fireplace a significant source of wood heat with the contemporary style of the Neo 1.6 wood burning insert. Built with heavy-gauge steel, this wood insert features our industry-leading secondary combustion system, our unique high capacity stainless steel baffle and advanced heat exchanger technology for exceptional clean-burning, efficient performance.

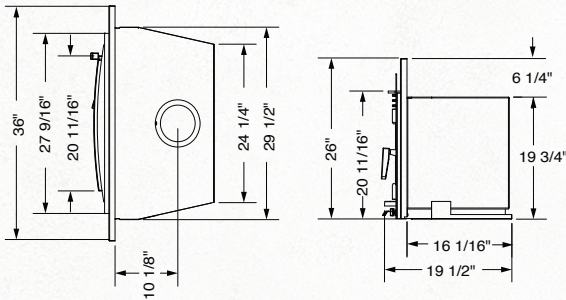

METALLIC BLACK



BRUSHED STAINLESS

STANDARD FEATURES

- EPA Certified
- Reliable, durable non-catalytic technology
- Air wash system for super clean ceramic glass
- High-tech multi-port combustion air injection system
- Inside and outside combustion air capable
- Floating firebox for extended stove life
- Rich Metallic Black finish
- 304 Stainless Steel Baffle, insulation cover, rails and flame shield
- Boost air for easy lighting
- Extended Burn Technology (EBT2)
- Two 45 cfm temperature actuated variable speed blower/s

- Single-Lever Air Control
- Removable flue collar for ease of installation
- East-West loading
- Integrated Heat Exchanger

DESIGN OPTIONS

- Contemporary Surround in Metallic Black or Stainless Steel (36" x 26")
- Oversize Surround (46" x 30")

MINIMUM FIREBOX OPENING

- Min. Fireplace Opening Front Width 30"
- Min. Fireplace Opening Front Height 20"
- Min. Fireplace Opening Front Depth 17"



AVAILABLE SURROUNDS



METALLIC BLACK



BRUSHED STAINLESS STEEL

For reference only. Installations should be based on installation manuals. Specifications subject to change.