

GAS INSERT

TOFINO *i40S*



Shown with: Modern Black Front, Split Log Burner Media, Ledgestone Panels

BTU Input NG	40,000
BTU Input LP	35,000
P.4.1-15 Efficiency NG	77.6%
P.4.1-15 Efficiency LP	78.5%

Unit Dimensions

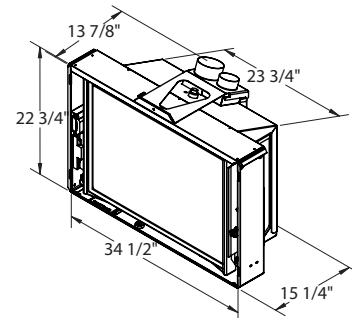

Standard Features

- SIT Proflame 2 Valve System (120V)
- Split-Flow Burner to Maximize Flame Control
- Built in blower
- Interior Firebox Lighting
- Remote Control or Manual Control
- Burner Base (Burner Media package sold separately)
- Design-A-Fire Interior Options
- No-Tool Decorative Front Installation
- Multiple Decorative Front Options
- Integrated Stainless Steel Micro-Mesh Safety Screen
- Integrated Leveling System
- Easy Venturi and Flue Damper Adjustment
- Easy Access to Module, Valve, and Gas Shut Off
- Centered Side-by-Side Venting, 3x4 Collinear
- NG or LP Dedicated Units

Backing Plates

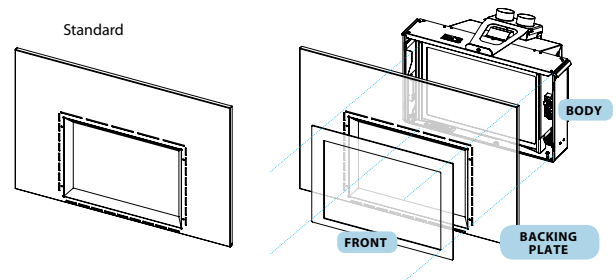

Regular 28" x 42"
Oversize 31" x 44"

For reference only. Installations should be based on manuals and rating labels. Specifications subject to change.

BURNER MEDIA



Split Log



Black Glass



Twilight Glass

FIREBOX PANELS



Ledgestone



Red Brick



Grey Fluted



Black Porcelain

DECORATIVE FRONTS



Artisan Black



Artisan Brushed Nickel



Modern Black



Modern Brushed Nickel

