

ESPRIT

LINEAR GAS FIREPLACE FOR MEDIUM TO LARGE SPACES

Natural Gas

30,000 BTU

26,000 BTU Liquid Propane

P.4.1-15 EFFICIENCY NG	72.1%
P.4.1-15 EFFICIENCY LP	72.1%
AFUE NG	77.5%
AFUE LP	79.1%
GLASS SIZE	320 sq.in.

The Esprit linear gas fireplace offers Pacific Energy's highest level of quality, technical innovation, and engineering in a modern landscape. For maximum heat and ultimate energy efficiency, the Esprit utilizes large formed steel heat exchangers and standard one-touch programmable remote controls to provide quick, easy control over heat and added energy savings. Even at the lowest settings, flames are appealingly rich and full to gently warm the room.

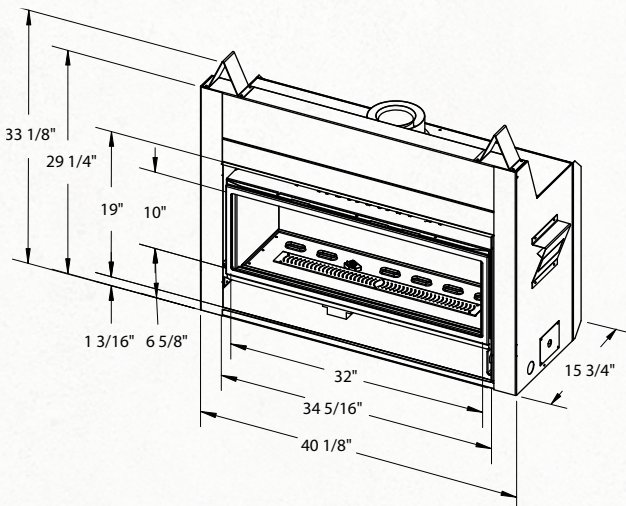

For reference only. Installations should be based on installation manuals. Specifications subject to change.



STANDARD FEATURES

- Direct vent technology
- SIT Pro Flame 2 valve
- High-efficiency heat exchanger with aluminum fins
- Integrated micro-mesh safety screen
- Standard remote control
- Variable-speed blower
- Mobile home approved
- Pre-installed in a factory built zero clearance kit

DESIGN OPTIONS

- Design-A-Fire
- Interiors: Porcelain Enamel (5 colours)
- Burners: Driftwood Logset or Glass
- Straight-Edge Surround available in Metallic Black
- Louvered Surround available in Metallic Black
- Contemporary Surround available in Metallic Black or Metallic Black with Stainless Steel accent
- Contemporary Surround 42 1/4" (W) x 22 1/2" (H)
- Louvered Surround 37" (W) x 21 1/2" (H)
- Straight-Edge Surround 42 1/4" (W) x 22 1/2" (H)

- DESIGN
- EFFICIENCY
- SAFETY
- DESIGN-A-FIRE
A SYSTEM BY PACIFIC ENERGY

